

## General Safety Information

### WARNING

- Check that the wheels are fastened securely before riding the bicycle. If the wheels are loose in any way, they may come off the bicycle and serious injury may result.
- **Obtain and read the service instructions carefully prior to installing the parts.** Loose, worn, or damaged parts may cause injury to the rider. We strongly recommend only using genuine Shimano replacement parts.
- Read these Technical Service Instructions carefully, and keep them in a safe place for later reference.

### Note

- Use the CS-M771-10 in combination with an MTB 10-speed chain.
- If the wheel becomes stiff and difficult to turn, you should lubricate it with grease.
- Do not apply any oil to the inside of the hub, otherwise the grease will come out.
- You should periodically wash the sprockets in a neutral detergent and then lubricate them again. In addition, cleaning the chain with neutral detergent and lubricating it can be an effective way of extending the useful life of the sprockets and the chain.
- If the chain keeps coming off the sprockets during use, replace the sprockets and the chain.
- Parts are not guaranteed against natural wear or deterioration resulting from normal use.
- For maximum performance we highly recommend Shimano lubricants and maintenance products.

## Technical Service Instructions

SI-3TG0A-002

# FH-M785 / HB-M785 FH-T780 / HB-T780

Freehub / Front hub

## Specifications

### Freehub / Front hub

Model No.	Freehub		Front hub	
	FH-M785	FH-T780	HB-M785	HB-T780
Gears	10		—	
No. of spoke holes	32 / 36		32 / 36	
Overlock nut dimensions	135 mm		100 mm	
Applicable brakes	Disc brake	Rim brake	Disc brake	Rim brake

### Cassette sprocket tooth combination

Model number	Group name	Gears	Tooth combination
CS-M771-10	<b>bJ</b>	10	11, 13, 15, 17, 19, 21, 23, 26, 30, 34T
	<b>bK</b>	10	11, 13, 15, 17, 19, 21, 24, 28, 32, 36T
	<b>bL</b>	10	11, 12, 14, 16, 18, 20, 22, 25, 28, 32T
CS-6700	—	10	11, 12, 13, 14, 15, 17, 19, 21, 24, 28T

\* The RD-M780 cannot be used in combination with the CS-6700 (11-28T).

\* The RD-T780 cannot be used in combination with the CS-M771-10 (11-36T).

\* Service Instructions in further languages are available at: <http://techdocs.shimano.com>

Please note: Specifications are subject to change for improvement without notice. (English)

# SHIMANO

SHIMANO AMERICAN CORPORATION

One Holland, Irvine, California 92618, U.S.A. Phone: +1-949-951-5003

SHIMANO EUROPE B.V.

Industrieweg 24, 8071 CT Nunspeet, The Netherlands Phone: +31-341-272222 3-77 Oimatsu-cho, Sakai-ku, Sakai-shi, Osaka 590-8577, Japan

© Jan. 2011 by Shimano Inc. AWS Printed in Malaysia.

### <FH-M785 / FH-T780>

## Installation of the HG sprockets

For each sprocket, the surface that has the group mark should face outward and be positioned so that the wide parts of the gear projections on each sprocket and the A part (where the groove width is wide) of the freewheel body are aligned.

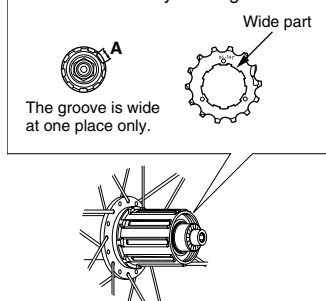

### <CS-M771-10>

(bJ) 11 - 34T  
(bK) 11 - 36T  
(bL) 11 - 32T

### <CS-6700>

11 - 28T

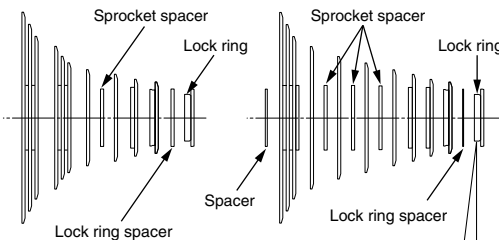

For installation of the HG sprockets, use the special tool (TL-LR15/LR10) to tighten the lock ring.

**Tightening torque:**  
30 - 50 N·m {261 - 435 in. lbs.}

To replace the HG sprockets, use the special tool (TL-LR15/LR10) and TL-SR21 to remove the lock ring.

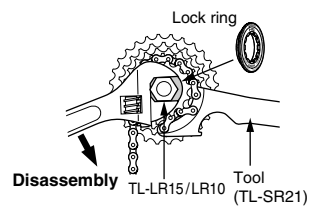

## Replacement of the freewheel body

First, pull out the hub axle by following the procedure shown in the illustration. (FH-M785) The double-lock section at the freewheel side cannot be disassembled.

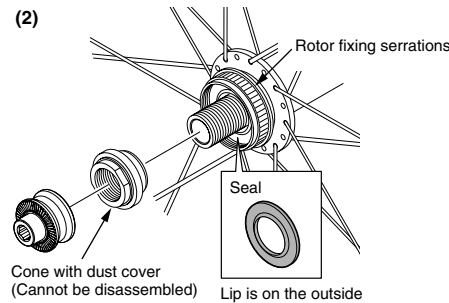
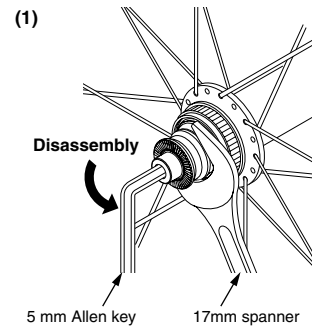

**Left side Tightening torque:**  
15 - 20 N·m {131 - 174 in. lbs.}

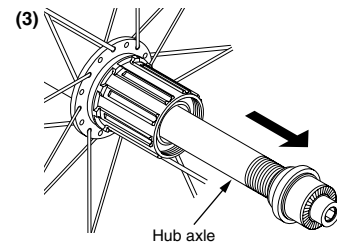

### Note:

- When removing and installing the seal, do it very carefully so that the seal does not become bent. When reinstalling the seal, make sure that it is facing the right way, and insert it as far as it will go.
- Do not disassemble the dust-proof cover which is crimped onto the cone.
- The rotor fixing serrations may become damaged if the disc brake rotor has not been installed to the FH-M785, so install the accessory rotor mount cover.

After removing the hub axle, remove the freewheel body fixing bolt (inside the freewheel body), and then replace the freewheel body.

### Note:

**Be sure to apply grease to the the thread of the freewheel body fixing bolt, otherwise looseness or sticking may occur.**  
**Do not attempt to disassemble the freewheel body, because it may result in a malfunction.**

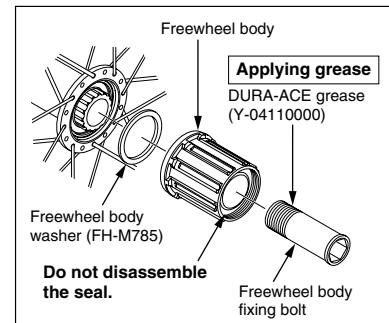
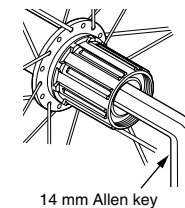

**Tightening torque:**  
45 - 50 N·m {392 - 435 in. lbs.}

### <HB-M785>

## Maintenance

The unit can be disassembled as shown in the illustration. Apply grease to the various parts at periodic intervals.

### Note:

- The HB-M785 cannot be disassembled from the left side of the hub unit (the rotor fixing serration side).
- When removing and installing the seal, do it very carefully so that the seal does not become bent. When reinstalling the seal, make sure that it is facing the right way, and insert it as far as it will go.
- The rotor fixing serrations may become damaged if the disc brake rotor has not been installed to the HB-M785, so install the accessory rotor mount cover.

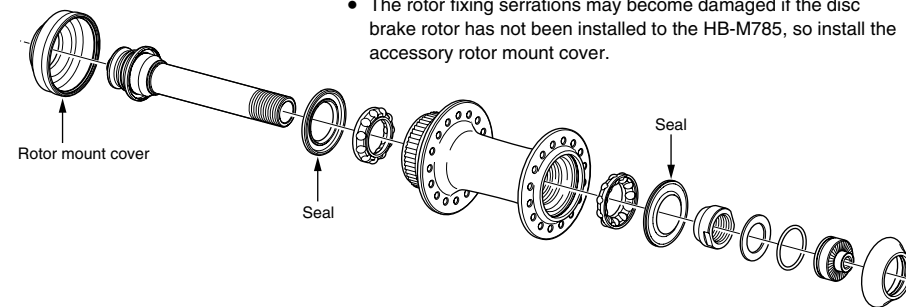

### <Assembly>

Use the special tool (TL-HS22/HS20 /17mm) for installing the hub axle and a 5 mm Allen key to tighten the lock nut so as to double-lock the mechanism as shown in the illustration.

**Tightening torque:**  
15 - 17 N·m {131 - 148 in. lbs.}

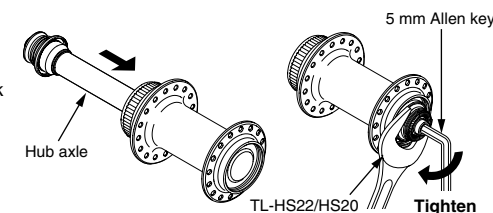

### <FH-M785 / HB-M785>

## Wheel spoke lacing

Check that the spokes have been laced as shown in the illustration. A radial assembly cannot be used.

### Rotating direction of wheel

Front left Rear left Rear right Front right

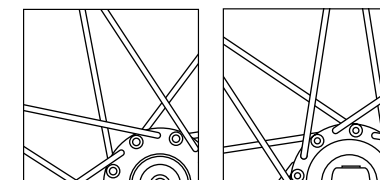

## Installation of the rotor

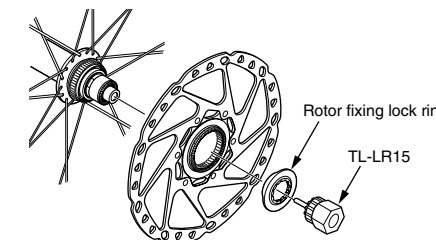

**Tightening torque:**  
40 - 50 N·m {348 - 435 in. lbs.}