

Dealer's Manual

Disc Brake

BR-M987
BR-M820
BR-M785
BR-M675
BR-M640
BR-M615
BR-M395
BR-T675
BR-T615

BL-M988-B
BL-M987
BL-M820-B
BL-M820
BL-M785-B
BL-M675-B
BL-M675
BL-M640-B
BL-M640
BL-M615
BL-M395
BL-T785-B
BL-T675-B
BL-T675
BL-T615

IMPORTANT NOTICE

- This dealer's manual is intended primarily for use by professional bicycle mechanics.

Users who are not professionally trained for bicycle assembly should not attempt to install the components themselves using the dealer's manuals.

If any part of the information on the manual is unclear to you, do not proceed with the installation. Instead, contact your place of purchase or a local bicycle dealer for their assistance.

- Make sure to read all instruction manuals included with the product.
- Do not disassemble or modify the product other than as stated in the information contained in this dealer's manual.
- All dealer's manuals and instruction manuals can be viewed on-line on our website (<http://si.shimano.com>).
- Please observe the appropriate rules and regulations of the country, state or region in which you conduct your business as a dealer.

For safety, be sure to read this dealer's manual thoroughly before use, and follow it for correct use.

The following instructions must be observed at all times in order to prevent personal injury and physical damage to equipment and surroundings.

The instructions are classified according to the degree of danger or damage which may occur if the product is used incorrectly.

 **DANGER**

Failure to follow the instructions will result in death or serious injury.

 **WARNING**

Failure to follow the instructions could result in death or serious injury.

 **CAUTION**

Failure to follow the instructions could cause personal injury or physical damage to equipment and surroundings.

TO ENSURE SAFETY

WARNING

- **When installing components, be sure to follow the instructions that are given in the instruction manuals.**

It is recommended that you use only genuine Shimano parts. If parts such as bolts and nuts become loose or damaged, the bicycle may suddenly fall over, which may cause serious injury.

In addition, if adjustments are not carried out correctly, problems may occur, and the bicycle may suddenly fall over, which may cause serious injury.

-  Be sure to wear safety glasses or goggles to protect your eyes while performing maintenance tasks such as replacing parts.
- After reading the dealer's manual thoroughly, keep it in a safe place for later reference.

Be sure to also inform users of the following:

< SAINT/ZEE >

- **Downhill bicycle riding and freeriding are inherently dangerous activities. There is a risk of being involved in an accident that can result in a serious injury or even death. It is strongly recommended that riders wear protective head and body gear and perform thorough safety checks of their bicycles before riding. Please remember that you are riding at your own risk and that you have to consider your experience and your skills very carefully.**

- The brake system is designed for downhill bicycle riding and freeriding, and its braking performance is much higher than for other brakes. Riders must become accustomed to the higher performance of this brake in a controlled environment before riding the bicycle as described above. If you do not familiarize yourself with the performance level of this brake, you may be involved in an accident that could result in serious injury or even death.

Furthermore, the performance of the brakes makes them unsuitable for riding on city streets. If riding the bicycle on streets is unavoidable, take extreme care while doing so.

- The 203 mm and 180 mm rotors provide a higher braking force than the 160 mm rotors. Make sure that you have a complete feel for the braking characteristics before using the brakes.
- It is important to completely understand the operation of your bicycle's brake system. Improper use of your bicycle's brake system may result in a loss of control or a fall, which could lead to severe injury. Because each bicycle may handle differently, be sure to learn the proper braking technique (including brake lever pressure and bicycle control characteristics) and operation of your bicycle. This can be done by consulting your professional bicycle dealer and the bicycle's owners manual, and by practicing your riding and braking technique.
- Please use extra caution to keep your fingers away from the rotating disc brake rotor. The disc brake rotor is sharp enough to inflict severe injury to your fingers if caught within the openings of moving disc brake rotor.



- The calipers and disc brake rotor will become hot when the brakes are operated, so do not touch them while riding or immediately after dismounting from the bicycle, otherwise you may get burned.
- Be careful not to allow any oil or grease to get onto the disc brake rotor and brake pads, otherwise the brakes may not work correctly.
- If any oil or grease does get on the brake pads, you should consult a dealer or an agency. There is the danger that the brakes may not work correctly.

- If noise occurs during brake operation, the brake pads may have been worn down to the usable limit. Check that the brake system temperature has been cooled down sufficiently, check the thickness of the brake pad. If the thickness is 0.5 mm or below, the brake pad needs to be replaced with a new one. Consult a dealer or an agency.

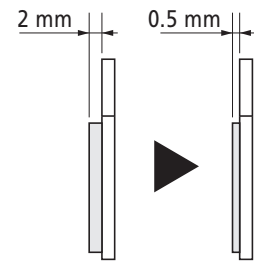

- If the disc brake rotor is cracked or deformed, immediately stop using the brakes and consult a dealer or an agency.
- If the disc brake rotor becomes worn down to a thickness of 1.5 mm or less, or if the aluminum surface appears, immediately stop using the brakes and consult a dealer or an agency. The disc brake rotor may break, and you may fall off the bicycle.
- Vapor lock may occur if the brakes are applied continuously. To relieve this condition, momentarily release the lever.

Vapor lock is a phenomenon in which the oil inside the brake system becomes heated, which causes any water or air bubbles inside the brake system to expand. This can then result in a sudden increase in the brake lever stroke.

- The disc brake is not designed to work with the bicycle upside down. If the bicycle is turned upside down or on its side, the brake may not work correctly, and a serious accident could occur. Before riding the bicycle, be sure to operate the brake lever a few times to check that the brakes operate normally. If the brakes do not operate normally, stop using the brakes and consult a dealer or an agency.
- If you feel no resistance when depressing the brake lever, immediately stop using the brakes and consult a dealer or an agency.
- If fluid leaks occur, immediately stop using the brakes and consult a dealer or an agency.
- If the front brake is applied too strongly, the wheel may lock and the bicycle may fall forward, and serious injury may result.
- Always make sure that the front and rear brakes are working correctly before you ride the bicycle.
- The required braking distance will be longer during wet weather. Reduce your speed and apply the brakes early and gently.
- If the road surface is wet, the tires will skid more easily. If the tires skid, you may fall off the bicycle. To avoid this, reduce your speed and apply the brakes early and gently.
- The lever should never be processed because of the properties of carbon. Otherwise, the lever may break, and braking may become disabled.
- Check before riding that there is no damage such as carbon separation or cracking. If there is any damage, stop using the bicycle and consult a dealer or an agency. Otherwise, the lever may break, and braking may become disabled.

For Installation to the Bicycle, and Maintenance:

- Please use extra caution to keep your fingers away from the rotating disc brake rotor during installing or servicing the wheel. The disc brake rotor is sharp enough to inflict severe injury to your fingers if caught within the openings of moving disc brake rotor.



- If the disc brake rotor is cracked or warped, be sure to replace it with a new disc brake rotor.
- If the disc brake rotor becomes worn down to a thickness of 1.5 mm or so that the aluminum surface becomes visible, be sure to replace the disc brake rotor with a new one.
- Check that the brake components have cooled down sufficiently before attempting to adjust the brakes.

- Use only Shimano genuine mineral oil. If other types of oil are used, it may cause problems with brake operation, and cause the system to be unuseable.
- Be sure to use only oil from a freshly-opened container, and do not re-use oil which has been drained from the bleed nipple. Old oil or already-used oil may contain water which could cause vapor lock in the brake system.
- Be careful not to let water or air bubbles to get into the brake system, otherwise vapor lock may occur. Be particularly careful when removing the cover of the reservoir tank.
- If cutting the brake hose in order to adjust the length of the brake hose, or when changing over the brake hose from left to right or vice versa, be sure to bleed the air from the brake hose according to the steps given in "Adding Shimano genuine mineral oil and bleeding air".
- When turning the bicycle upside down or on its side, the brake system may have some air bubbles inside the reservoir tank which are still there when the bleed screw is closed, or which accumulate in various parts of the brake system when it is used for long periods. This disc brake system is not designed to work with the bicycle upside down. If the bicycle is turned upside down or on its side, the air bubbles inside the reservoir tank may move in the direction of the calipers. If the bicycle is ridden in this condition, there is the danger that the brakes may not operate and a serious accident could occur. If the bicycle has been turned upside down or on its side, be sure to operate the brake lever a few times to check that the brakes operate normally before riding the bicycle. If the brakes do not operate normally, adjust them according to the following procedure.

If brake does not seem to work (feels sluggish) when the lever is depressed

Set the brake lever so that it is parallel to the ground, and then gently depress the brake lever several times and wait for the bubbles to return to the reservoir tank. It is recommended that you then remove the reservoir tank cover and fill the reservoir tank with mineral oil until no bubbles remain.

If the brakes still operate sluggishly, bleed the air from the brake system. (Refer to "Adding the Shimano genuine mineral oil and bleeding air".)

- If the quick release lever is on the same side as the disc brake rotor, there is the danger that it may interfere with the disc brake rotor, so check that it does not interfere.
- Shimano disc brake systems are not compatible with tandem bicycles. Because tandem bicycles have a high overall weight, the load on the brake system increases during brake operation. If hydraulic disc brakes are used with tandem bicycles, the oil temperature will become too high and vapor locks or ruptures in the brake hoses may occur, and this will cause the brakes to fail.

< SM-RTAD05 Disc rotor adapter >

- Disc rotors with diameters of up to 203 mm can be installed. If disc rotors with a larger diameter than this are installed, the braking force may damage the main unit.

< Brake hose >

- After installing the brake hose to the brake unit, adding Shimano genuine mineral oil and bleeding air bubbles, depress the lever again several times to check that the brakes are operating normally and there are no fluid leaks from the brake hose or the system.
- The connector insert is for this brake hose only. Use an appropriate connector insert according to the following table. Use of a connector insert incompatible with the brake hose may cause fluid leaks.

Model No.	Length	Color
SM-BH90	11.2 mm	Silver
SM-BH59 / 80	13.2 mm	Gold
YM-BH81	13.2 mm	Silver

- Do not reuse the olive piece or the connector insert when reinstalling. A damaged or reused olive or the connector insert may not provide secure brake hose connection, possibly causing the brake hose to disconnect from the calipers or brake lever. If the brake hose becomes disconnected, there is the danger that the brakes may suddenly stop working.

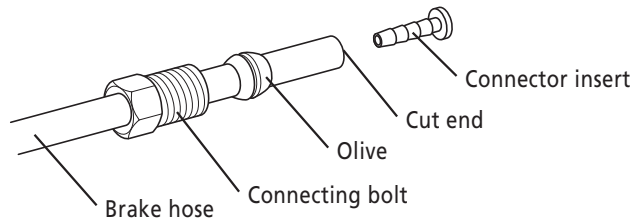

- Cut the brake hose so that the cut end is perpendicular to the length of the brake hose. If the brake hose is cut at an angle, fluid leaks may result.

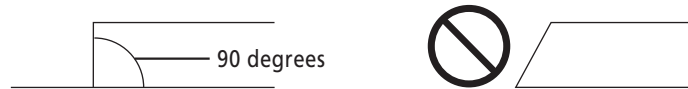

CAUTION

Be sure to also inform users of the following:

■ Cautions on the Shimano genuine mineral oil

- Contact with eyes may result in irritation. In the event of eye contact, flush with fresh water and seek medical assistance immediately.
- Contact with skin may cause a rash and discomfort. In the event of skin contact, wash well with soap and water.
- Inhalation of Shimano genuine mineral oil mist or vapors may cause nausea. Cover nose and mouth with a respirator type mask and use in a well ventilated area. If Shimano genuine mineral oil mist or vapor is inhaled, go immediately to an area with fresh air. Cover up with a blanket. Stay warm and stable and seek professional medical advice.

■ Burn-in period

- Disc brakes have a burn-in period, and the braking force will gradually increase as the burn-in period progresses. Make sure that you are aware of any such increases in braking force when using the brakes during the burn-in period. The same thing will happen when the brake pads or disc brake rotor are replaced.

For Installation to the Bicycle, and Maintenance:

- When using the special tool (TL-FC36) to remove and install the rotor mounting ring, be careful not to touch the outside of the disc brake rotor with your hands. Wear gloves to protect your hands from getting cut.

■ Handling the Shimano genuine mineral oil

- Use safety glasses when handling, and avoid contact with eyes. Contact with eyes may result in irritation. In the event of eye contact, flush with fresh water and seek medical assistance immediately.
- Use gloves when handling. Contact with skin may cause a rash and discomfort. In the event of skin contact, wash well with soap and water.
- Do not drink. May cause vomiting or diarrhea.
- Keep out of reach of children.
- Do not cut, heat, weld or pressurize the oil container, as this may cause explosion or fire.
- Disposal of Used Oil: Follow local county and/or state codes for disposal. Use care when preparing oil for disposal.
- Directions: Keep the container sealed to prevent foreign objects and moisture from getting inside, and store it in a cool, dark area away from direct sunlight or heat.

■ When cleaning with a compressor

- If disassembling the caliper body to clean the internal parts using a compressor, note that moisture from the compressed air may remain on the caliper components. Let the caliper components dry sufficiently before reassembling the calipers.

< Brake hose >

- When cutting the brake hose, handle the knife carefully so as not to cause injury.
- Be careful to avoid injury from the olive.

NOTE

Be sure to also inform users of the following:

- When the bicycle wheel has been removed, it is recommended that pad spacers should be installed. Do not depress the brake lever while the wheel is removed. If the brake lever is depressed without the pad spacers installed, the pistons will protrude further than is normal. If that happens, consult a dealer.
- Use soapy water or a dry cloth when carrying out cleaning and maintenance of the brake system. Do not use commercially-available brake cleansers or silencing agents, as they can cause damage to parts such as seals.
- In the case of carbon levers, wash them by using a soft cloth. Be sure to use a neutral detergent. Otherwise, the material may get damaged, and the strength may be affected.
- Avoid leaving the carbon levers in places where high temperatures are present. Also keep them well away from fire.
- Products are not guaranteed against natural wear and deterioration from normal use and aging.
- For maximum performance we highly recommend Shimano lubricants and maintenance products.

< SAINT/ZEE >

- This product is not warranted against damage resulting from use such as jumping while riding or if the bicycle falls over, except if such malfunctions result from non conforming materials or manufacturing methods.

For Installation to the Bicycle, and Maintenance:

- The 203 mm and 180 mm rotors have a larger diameter than the 160 mm rotor for cross-country bicycles, and so the flexing of these disc brake rotors is greater. As a result, they will interfere with the brake pads.
- If the brake caliper mounting boss and the dropout are not parallel, the disc brake rotor and caliper may touch.
- When the bicycle wheel has been removed, it is recommended that pad spacers should be installed. The pad spacers will prevent the piston from coming out if the brake lever is depressed while the wheel is removed.
- If the brake lever is depressed without the pad spacers installed, the pistons will protrude further than is normal. Use a flat-tipped screwdriver or similar tool to push back the brake pads, while being careful not to damage the surfaces of the brake pads. (If the brake pads are not installed, use a flat-shaped tool to push the pistons straight back in, while being careful not to damage them.)
If it is difficult to push the brake pads or pistons back, remove the bleed screws and then try again. (Note that some oil may overflow from the reservoir tank at this time.)
- Use isopropyl alcohol, soapy water or a dry cloth when carrying out cleaning and maintenance of the brake system. Do not use commercially-available brake cleansers or silencing agents, as they can cause damage to parts such as seals.
- Do not remove the pistons when disassembling the calipers.
- If the disc brake rotor is worn, cracked or warped, it should be replaced.
- The caliper of BR-M987 and the master cylinder of BL-M987 are made of magnesium. Corrosion starts occurring when these components come into contact with parts made of other types of metal such as iron bolts. In the contact area, a potential difference is created in a water solution made up of rain water, liquid residue from washing, sweat, and moisture. This forms an electrochemical cell, resulting in an electrochemical reaction. To prevent this problem, each part is provided with a special-purpose surface-treatment. Use dedicated parts to prevent corrosion and its progression. For more details, refer to "Dedicated parts for magnesium products" in "MAINTENANCE".

< SM-RTAD05 Disc rotor adapter >

- When using this disc rotor adapter to install disc rotors, the structure of the adapter means that there will be more play than normal in the disc rotor. Because of this, the disc rotor may interfere with the brake pads. Furthermore, it may also interfere with the calipers in the radial direction (upward).
- This product cannot be used with the 6-bolt rotor that is installed with an aluminum adapter (SM-RT86/RT76).

The actual product may differ from the illustration because this manual is intended chiefly to explain the procedures for using the product.

INSTALLATION

* Refer to the disc brake section of General Operations for how to install the brake caliper, brake lever, and disc brake rotor.

List of tools to be used

The following tools are required to assemble the product.

Where to use	Tool
Mount adapter	5 mm Allen key
Disc brake rotor fixing bolts	#T15 torx
Disc brake rotor fixing lock ring	TL-FC36
Bleed screw	3 mm Allen key
Brake hose	Utility knife
Connector insert	TL-BH61
Connecting bolt	8 mm spanner
Banjo	3 mm Allen key
	4 mm Allen key (SLX)

■ Disc brake mount adapter (for 180 mm rotors)

SM-MA-F180P/P2

Place the adapter onto the caliper as shown in the illustration, and then install the adapter to the frame.

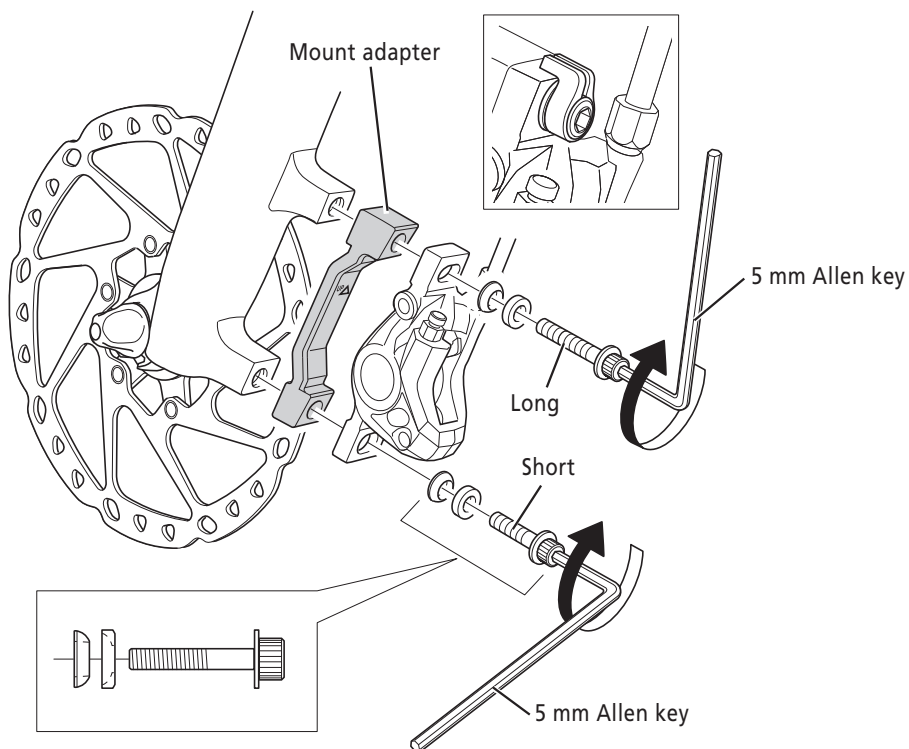

Tightening torque:
6.0 - 8.0 N·m {52 - 70 in. lbs}

■ Disc rotor adapter

SM-RTAD05

This product is an adapter to be used for installing a 6 bolt type disc rotor to a center lock system hub/wheel.

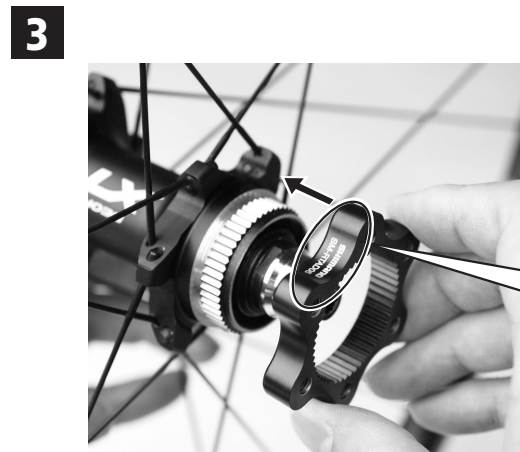

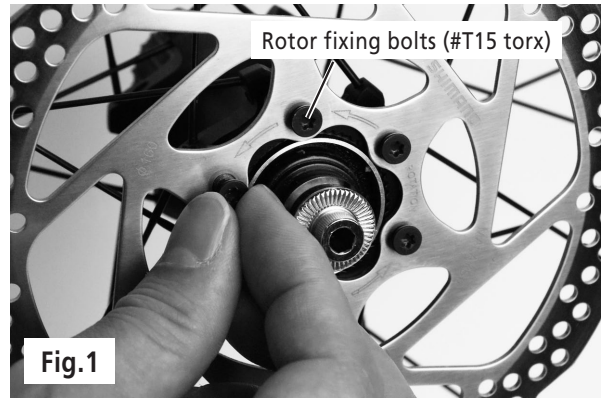

Install the rotor to the hub, and then temporarily install and tighten the bolts as shown in Figure 1.

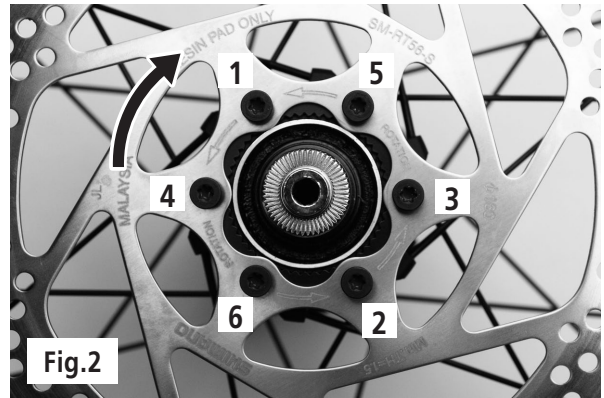
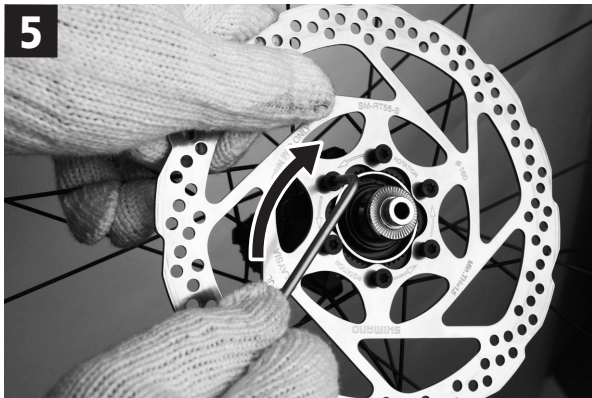

Tightening torque:
2.0 - 4.0 N·m {17 - 35 in. lbs}

Apply a force to the disc brake rotor to turn it in a clockwise direction as shown in Figure 2. While doing this, tighten the disc brake rotor fixing bolts in the order shown in the figure.





**Tightening torque:
40.0 N·m {350 in. lbs}**

MAINTENANCE

This section describes differences in specifications of products only not given in the disc brake section of General Operations.

■ Adding Shimano genuine mineral oil and bleeding air

BR-M395

When removing air from the caliper, you need a funnel.

Shimano genuine mineral oil replacement

It is recommended that you replace the oil inside the reservoir tank if it becomes severely discolored.

Attach a tube with a bag to the bleed nipple, and then open the bleed nipple and drain out the oil. You can operate the brake lever at this time to help the oil to drain out. After draining the fluid, pour in fresh brake fluid while referring to "Adding the Shimano genuine mineral oil and bleeding air". Use only Shimano genuine mineral oil.

Dispose of the waste oil according to proper country and/or state disposal regulations.

1. Set the brake lever so that it is in the riding position at a 45 degree angle to the ground. Remove the upper bleed screw, and set the oil funnel.

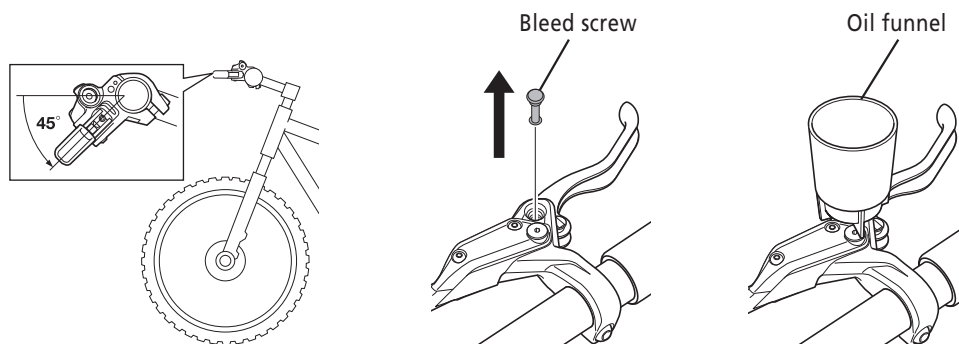

2. Remove the bleed nipple cap of the caliper, fill the syringe with oil, and connect the tube to the bleed nipple as shown in the illustration. Use a 3 mm Allen key to loosen the bleed screw by 1/8 of a turn to open it. Push the plunger of the syringe to add oil. The oil will then start coming out from the oil funnel. Continue adding oil until there are no more air bubbles mixed in with the oil that is coming out.

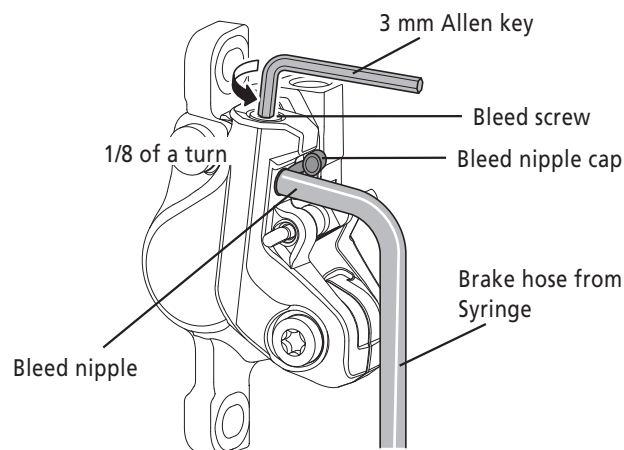

- 3.** Once there are no more air bubbles mixed in with the oil, temporarily close the bleed nipple.

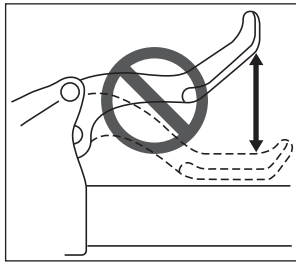

Do not continually squeeze and release the lever at this point.

If this is not observed, air bubbles may remain mixed in with the oil inside the caliper, and it will take longer to bleed the air. (If the lever is continually squeezed and released, drain out all of the oil and then add oil again.)

- 4.** Use a 3 mm Allen key to attach a bag to the tube as shown in the illustration. Connect the tube to the bleed nipple and loosen the bleed screw. After a little while, the oil and air bubbles will flow naturally from the bleed nipple into the tube. In this way it will be possible to easily extract the greater part of the air bubbles remaining inside the brake system. It may be effective to shake the brake hose gently, to tap the reservoir tank or calipers gently with a screwdriver, or to move the position of the calipers at this time.

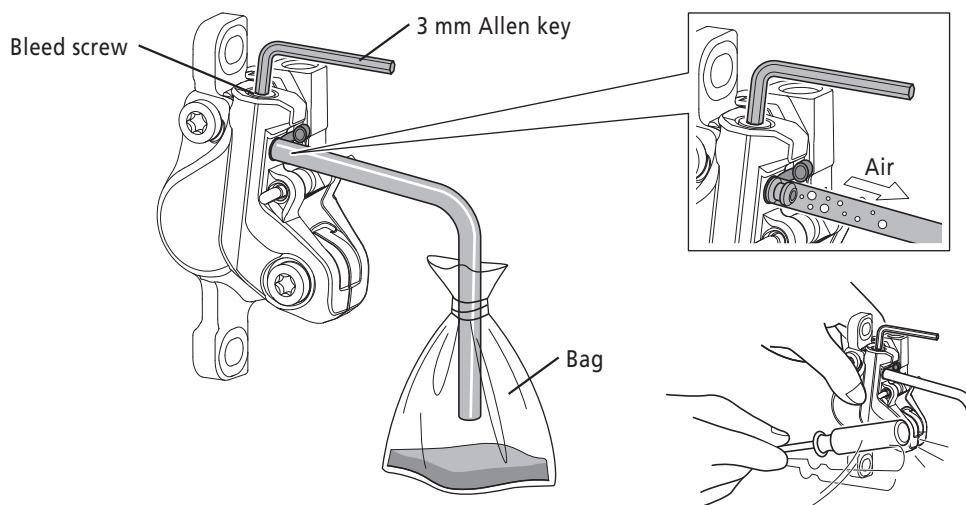

- 5.** The level of liquid inside the funnel will drop at this time, so keep filling the funnel with oil to maintain the level of liquid so that air is not drawn in (air does not get inside).

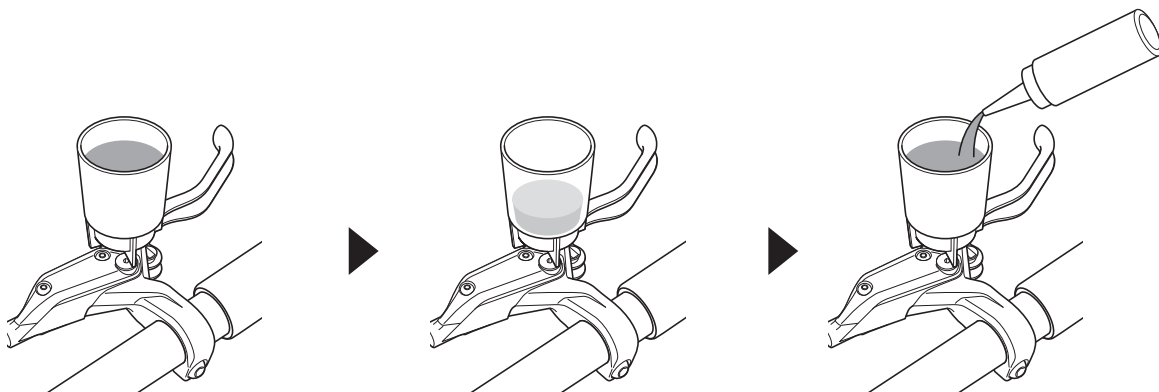

- 6.** Once no more air bubbles come from the bleed nipple, temporarily close the bleed screw.

7. With the brake lever depressed, open and close the bleed screw in rapid succession (for approximately 0.5 seconds each time) to release any air bubbles which may be in the calipers. Repeat this procedure about 2 to 3 times. Then tighten the bleed screw again.

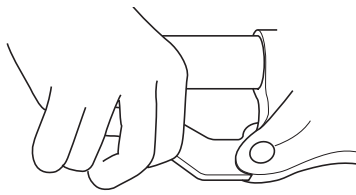

Tightening torque:
4.0 - 6.0 N·m {35 - 52 in. lbs.}

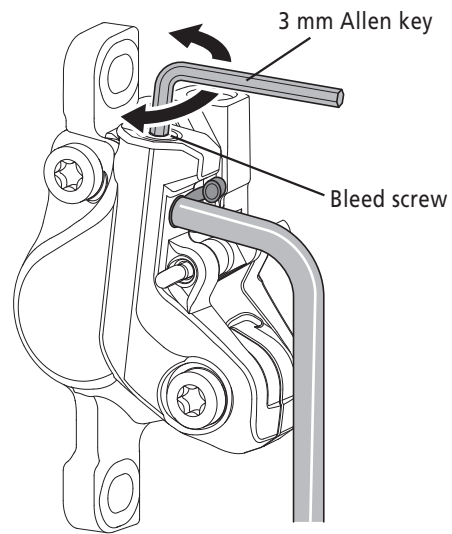

8. If the brake lever is then operated, air bubbles in the system will rise up through the port into the oil funnel. Once the bubbles stop appearing, depress the brake lever as far as it will go. The normal condition is for the lever to be stiff at this point.

Lever operation

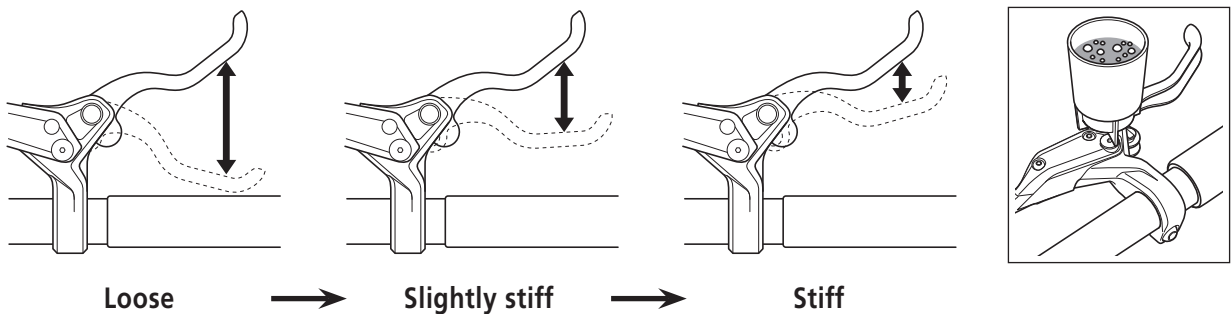

9. Set the lever unit to the horizontal position as shown in the illustration and tilt it in the direction of ① by 30 degrees, and then carry out step 8 to check that there is no air remaining. Next, tilt the lever unit 30 degrees in the direction of ②, and carry out step 8 again to check that there is no air remaining. If any air bubbles appear, repeat the above procedure until they stop appearing.

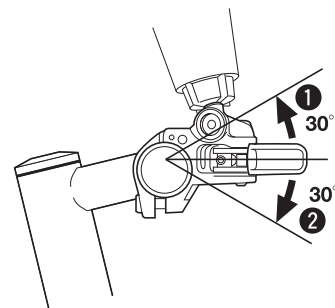

10. Remove the funnel, and while spilling out the oil so that no air bubbles remain in the reservoir tank, tighten the bleed screw.

* Do not operate the brake lever at this time, otherwise air may get inside the cylinder.

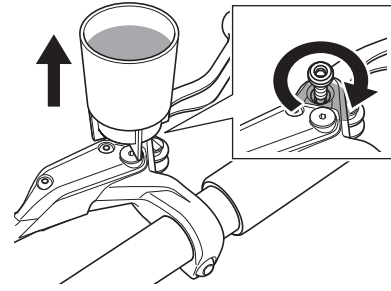

Tightening torque:
0.3 - 0.5 N·m {2.6 - 4.4 in. lbs.}

11. Wipe away any oil which has flowed out.

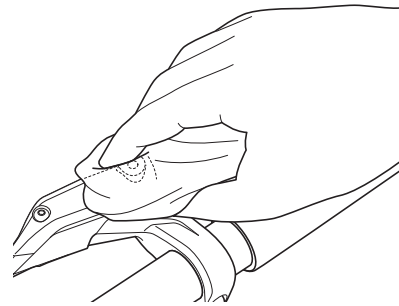

12. Finally, after removing the bleeding spacer and installing the pads and the pad spacer, depress the brake lever several times to check that the brake lever is operating normally and there are no fluid leaks from the brake hose or the system.

■ Cautions in the installation of the brake hose

- The installation position of the brake hose differs depending on the model.
- Do not let the brake hose become twisted when installing it.
- Make sure that the calipers and levers are in the positions shown in the illustrations.

< XTR >

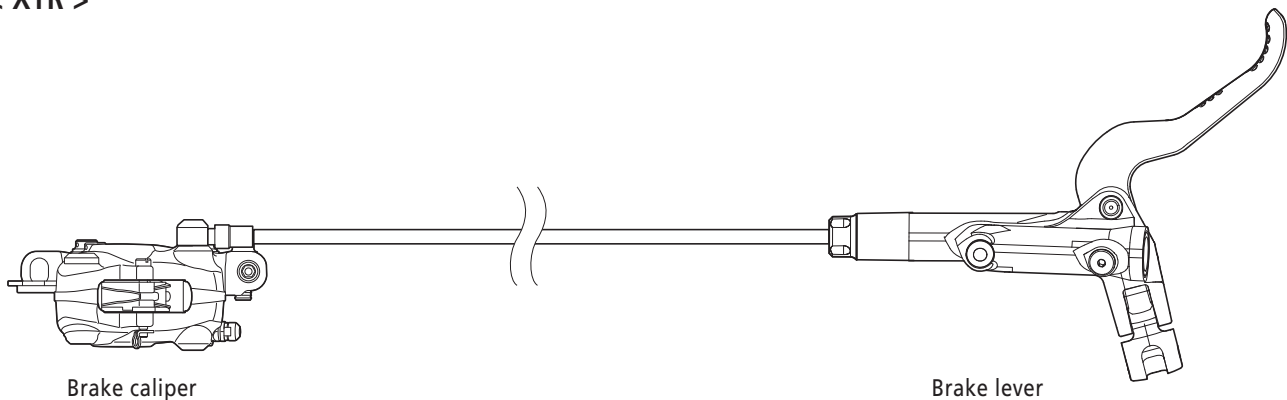

Brake caliper

Brake lever

< SAINT/ZEE >

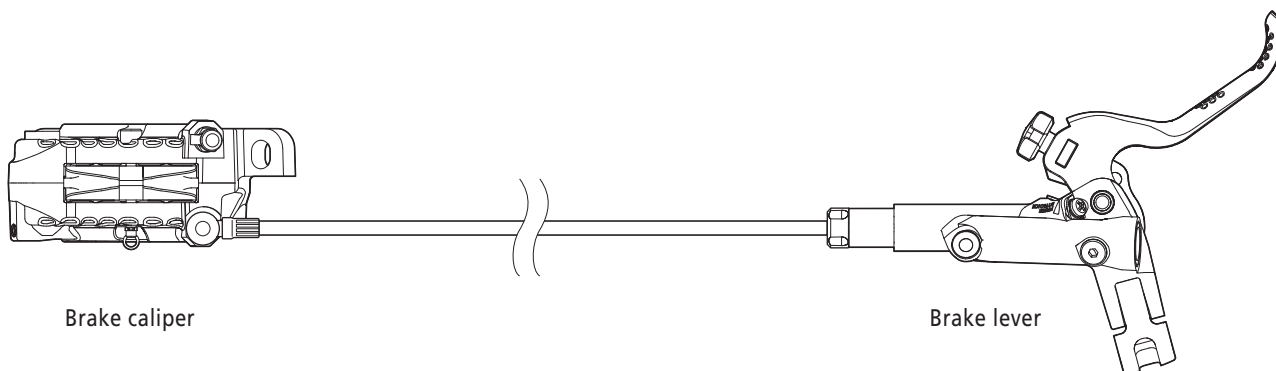

Brake caliper

Brake lever

< SLX >

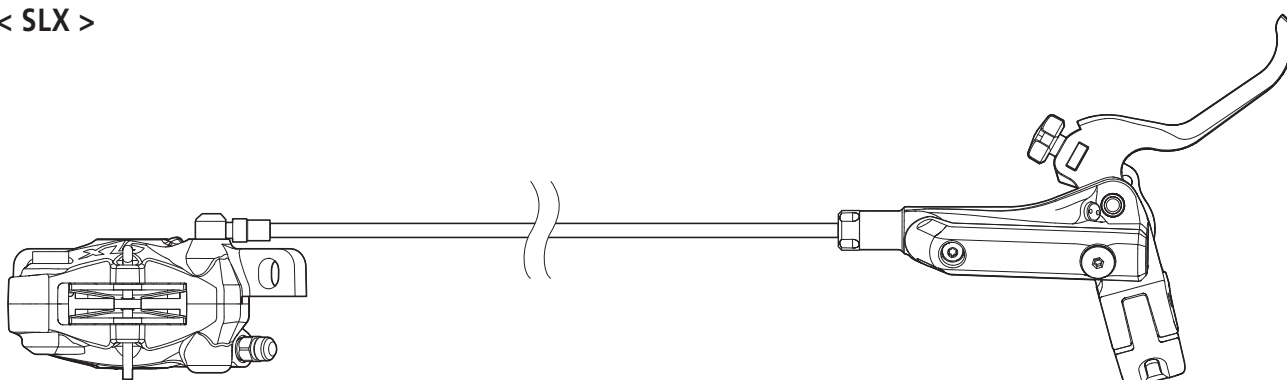

Brake caliper

Brake lever

< DEORE LX(Trekking)/DEORE(Trekking)/M395 >

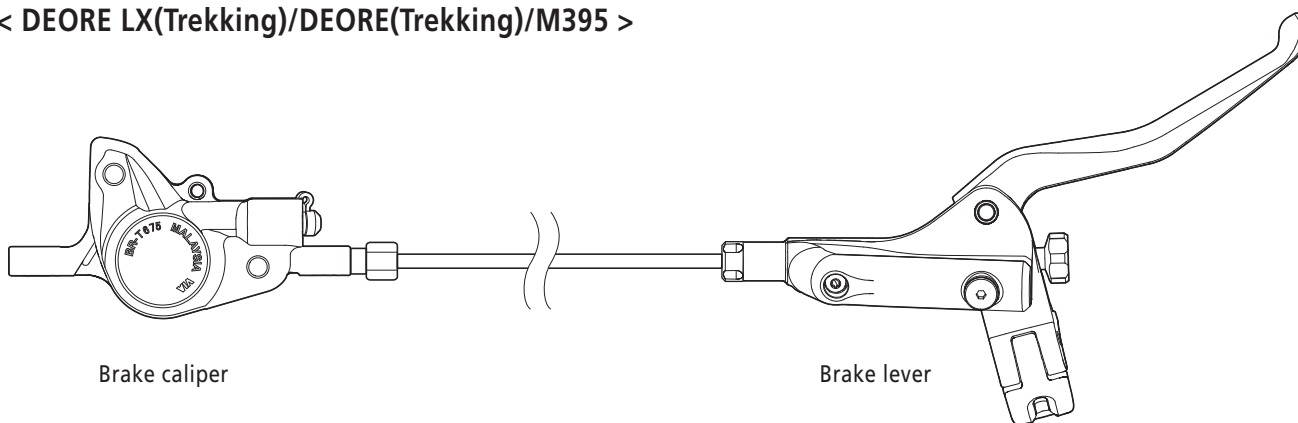

Brake caliper

Brake lever

Overview of the easy hose joint system

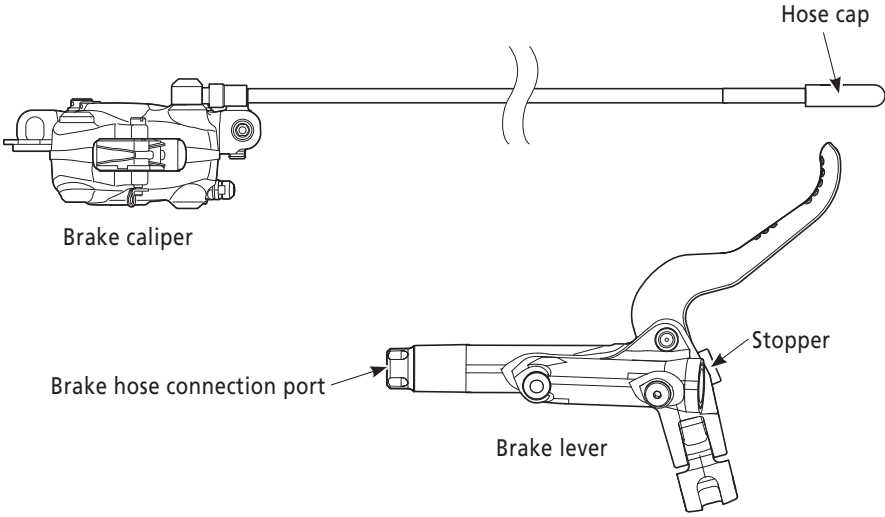

For information on how to install and replace the brake hose, refer to the brake section of General Operations.

■ Replacing the brake hose

BR-M395/BL-M395

1. Use a utility knife or similar tool to cut the brake hose.
 - * Make sure that you handle the utility knife safely and correctly in accordance with the instructions which are provided with the utility knife.
 - * If you are using TL-BH62, refer to the manual accompanying the product.

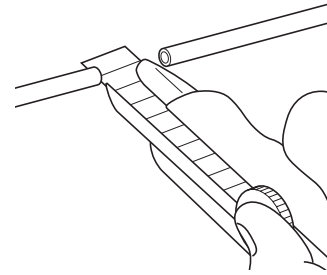

2. Pass the brake hose through the connecting bolt and the olive as shown in the illustration.

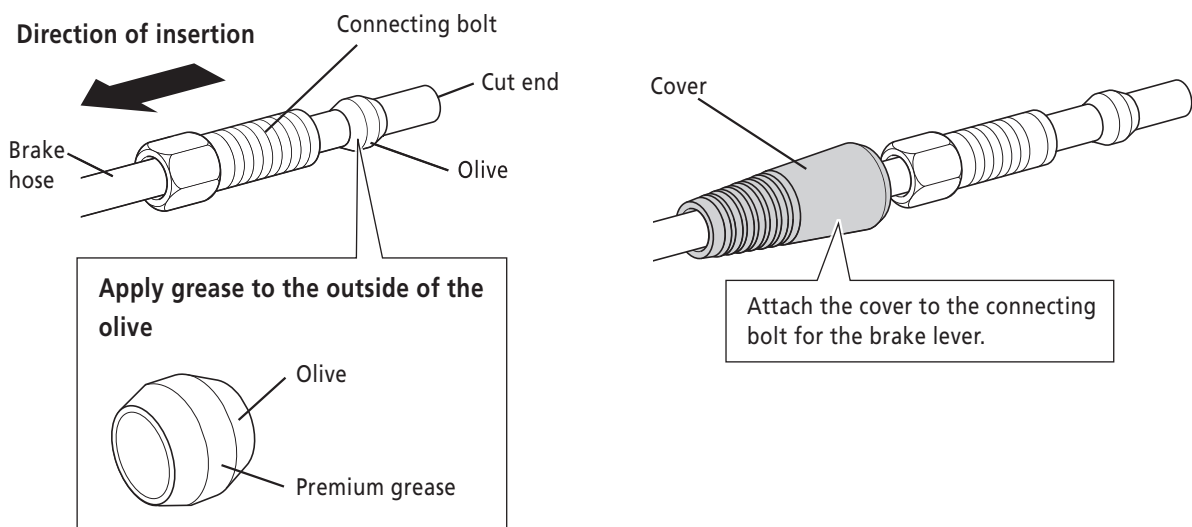

3. In order to check that the ends of the brake hose are fitted securely into the base of the brake hose mounts of the calipers and brake lever, make marks on the brake hose beforehand as shown in the illustration. (As a guide, the length of brake hose inside the mount should be approximately 11 mm, measured from the cut end of the brake hose.)

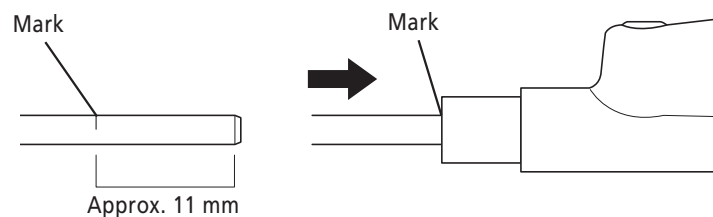

- 4.** Use an object such as a needle to smooth the inside of the cut end of the brake hose, and then install the connector insert. Attach the brake hose to the TL-BH61 as shown in the illustration, and secure the TL-BH61 in a vise. Then use a hammer or similar tool to knock the connector insert in firmly until the base of the connector insert touches the end of the brake hose. If the end of the brake hose is not touching the base of the connector insert, the brake hose may become disconnected or fluid leaks may occur.

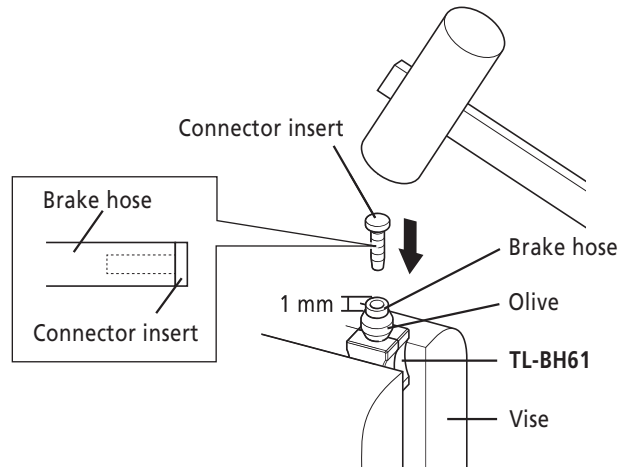

- 5.** After checking that the olive is positioned as shown in the illustration, apply premium grease to the threads of the connecting bolt and then attach the brake hose to the brake lever as shown in the illustration.

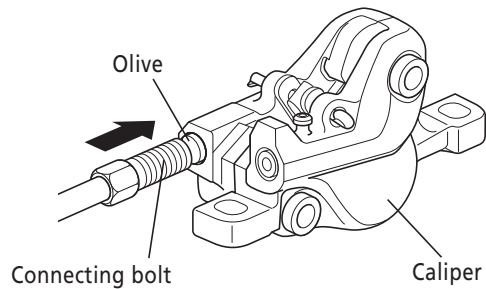
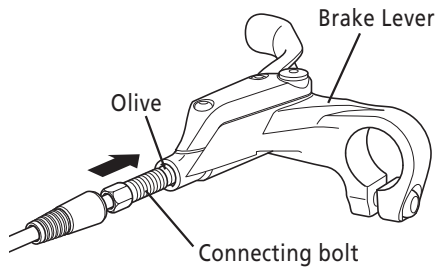
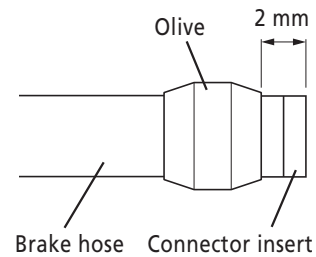

- 6.** While pushing the brake hose, tighten the connecting bolt.

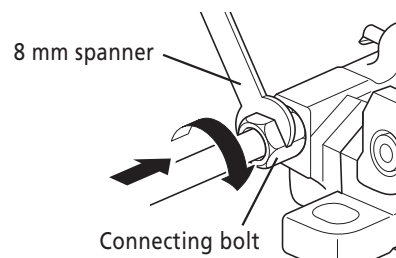

Tightening torque:
5.0 - 7.0 N·m {44 - 61 in. lbs.}

■ Replacing the brake hose on the caliper side

BR-T675/BR-T675-B

Mount the connecting bolt, the olive, and the connector insert to the brake hose by following the same procedure as for the brake lever. Use an 8 mm spanner to secure the connecting bolt.

1. Use a utility knife or similar tool to cut the brake hose.
 - * Make sure that you handle the utility knife safely and correctly in accordance with the instructions which are provided with the utility knife.
 - * If you are using TL-BH62, refer to the manual accompanying the product.

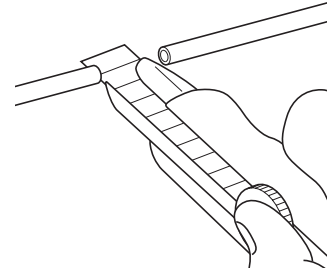

2. Pass the brake hose through the connecting bolt and the olive as shown in the illustration.

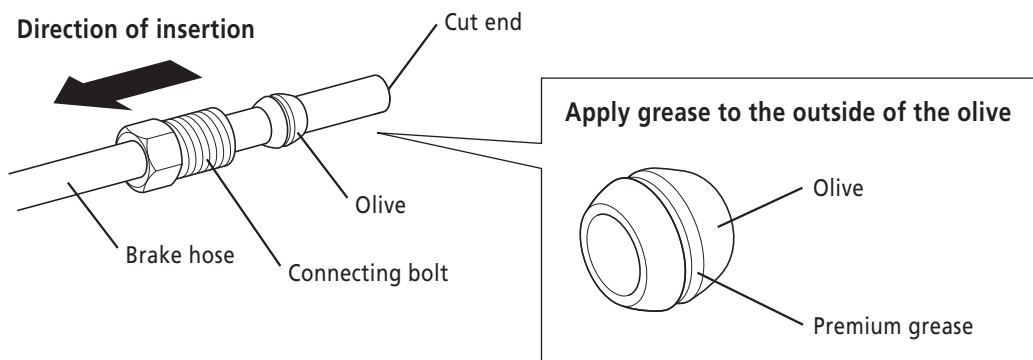

3. In order to check that the ends of the brake hose are fitted securely into the base of the brake hose mounts of the calipers, make marks on the brake hose beforehand as shown in the illustration. (As a guide, the length of brake hose inside the mount should be approximately 14 mm, measured from the cut end of the brake hose.)

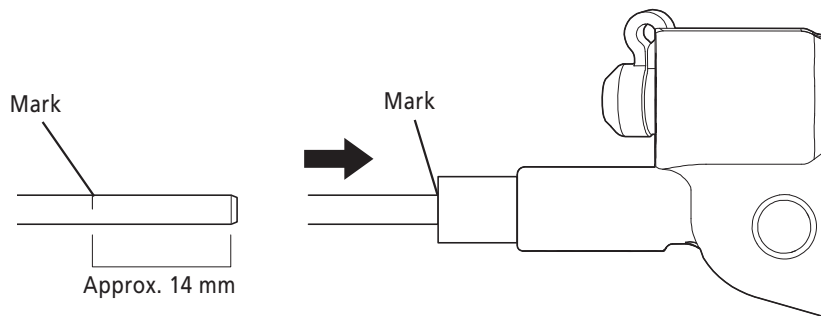

- 4.** Use an object such as a needle to smooth the inside of the cut end of the brake hose, and then install the connector insert. Attach the brake hose to the TL-BH61 as shown in the illustration, and secure the TL-BH61 in a vise. Then use a hammer or similar tool to knock the connector insert in firmly until the base of the connector insert touches the end of the brake hose. If the end of the brake hose is not touching the base of the connector insert, the brake hose may become disconnected or fluid leaks may occur.

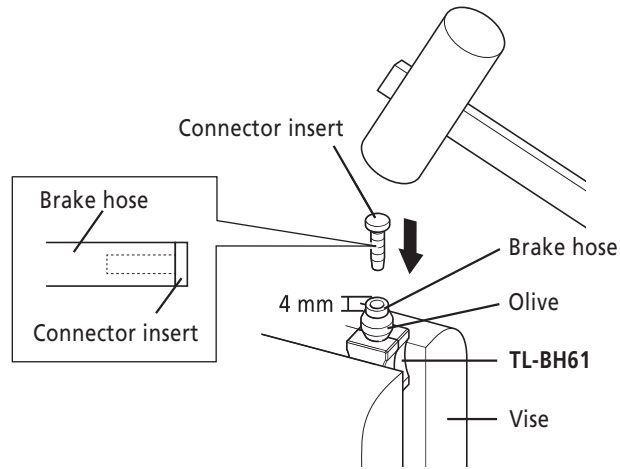

- 5.** After checking that the olive is positioned as shown in the illustration, apply premium grease to the threads of the connecting bolt and then attach the brake hose to the brake lever as shown in the illustration.

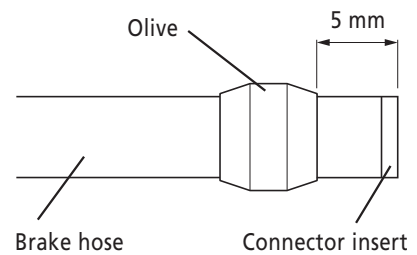

- Do not let the brake hose become twisted when installing it. Make sure that the calipers and brake levers are in the positions shown in the illustrations.

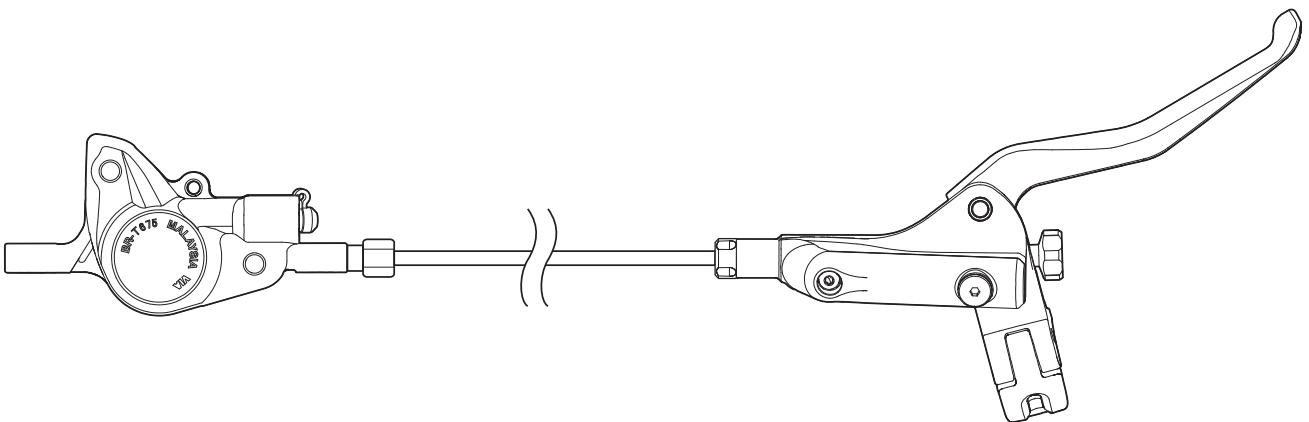

6. While pushing the brake hose, tighten the connecting bolt.

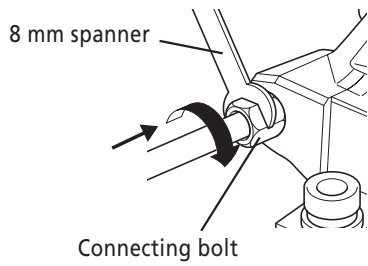

Tightening torque:
5.0 - 7.0 N·m {44 - 61 in. lbs.}

< M395/M615 >

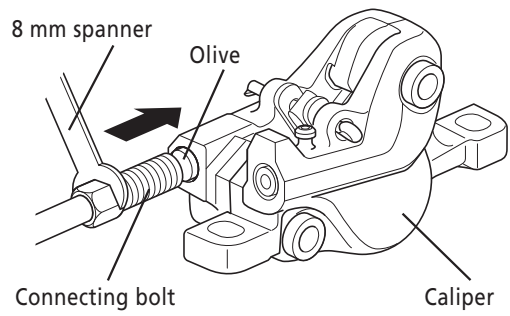

Tightening torque:
5.0 - 7.0 N·m {44 - 61 in. lbs.}

Banjo type

< XTR >

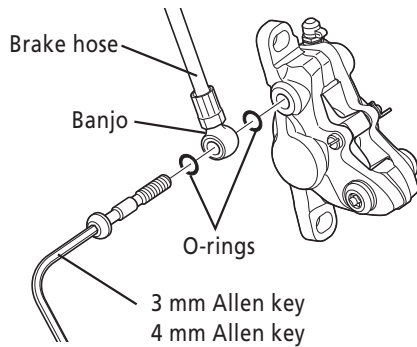

Tightening torque:
3 mm Allen key :
5.0 - 7.0 N·m {44 - 61 in. lbs.}
4 mm Allen key :
8.0 - 10.0 N·m {70 - 87 in. lbs.}

< SAINT/ZEE >

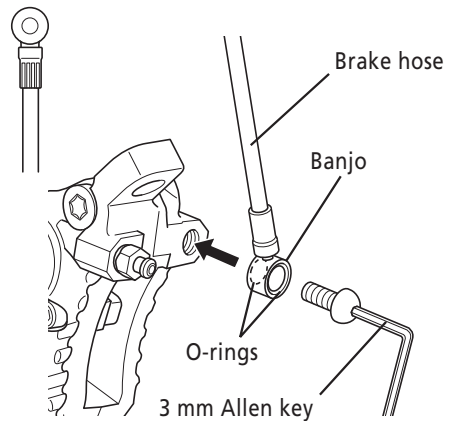

Tightening torque:
5.0 - 6.0 N·m {44 - 52 in. lbs.}

< SLX >

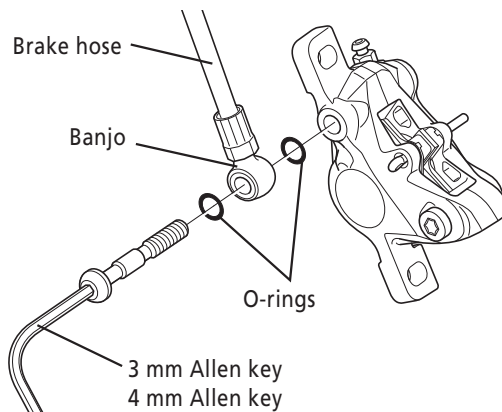

Tightening torque:
3 mm Allen key : 5.0 - 7.0 N·m {44 - 61 in. lbs.}
4 mm Allen key : 8.0 - 10.0 N·m {70 - 87 in. lbs.}

■ Brake pad replacement

Brake pad	M987/M820/M785	M675/M640/M615	T675/M395
Pad position (upper side)	×	×	—
Pad axle	×	—	—
Pad pin	—	×	×

* When replacing the brake pad from the above (when pushing back the piston), refer to the "Replacement of the brake pads" section of General Operations.

In the case of replacing the brake pads from the bottom (T675/M395/T675B)

Note:

The brake system is designed to automatically adjust the clearance between the disc brake rotor and the brake pads by the piston gradually protruding according to the wear of the brake pads. When you replace the brake pads, you need to push back the piston.

If oil adheres to the brake pads after oil is added, or if the brake pads are worn down to a thickness of 0.5 mm, or if the brake pad presser springs are interfering with the disc brake rotor, replace the brake pads.

1. Remove the wheel from the frame, and remove the brake pads as shown in the illustration.
2. Clean the pistons and surrounding area.

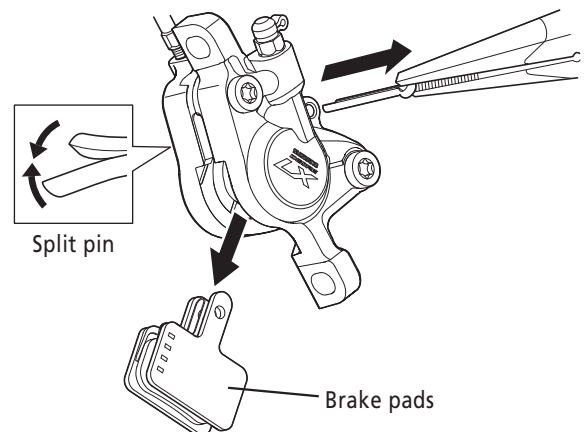

- 3.** Push the piston back in as far as it will go, while being careful not to twist it. (Note that some oil may overflow from the reservoir tank at this time.)

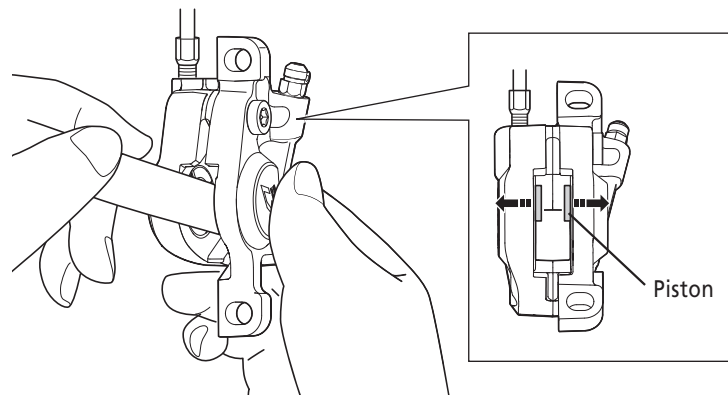

- 4.** Install the new brake pads, and then install the pad spacers (red). After this, bend open the split pin.

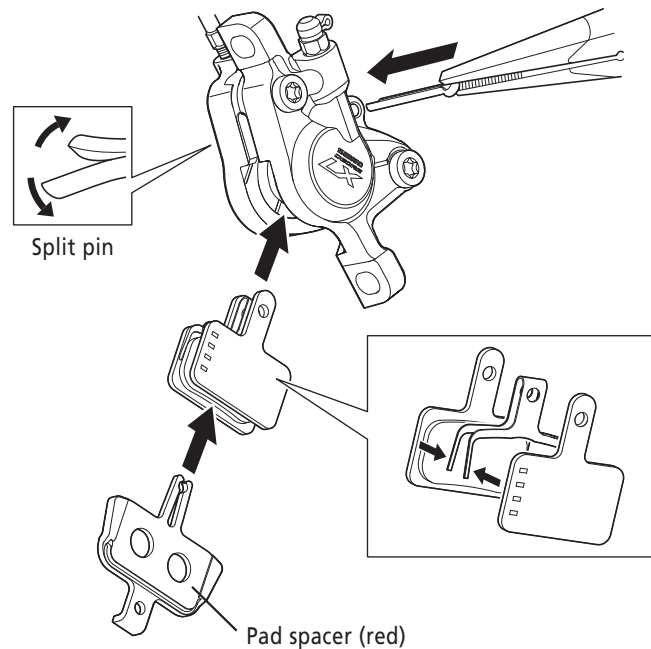

- 5.** Depress the brake lever several times to check that the operation becomes stiff.
- 6.** Remove the pad spacers, install the wheel, and then check that there is no interference between the disc brake rotor and brake pads. If they are touching, adjust while referring to the section "Installation of the disc brakes" in General Operations.
- 7.** After checking the oil level, replace the reservoir tank cover.
- 8.** Return the brake lever to its original position.

■ Dedicated parts for magnesium products

* Do not use any parts other than those listed below with BR-M987 or BL-M987, which are made of magnesium. The progression of corrosion accelerates.

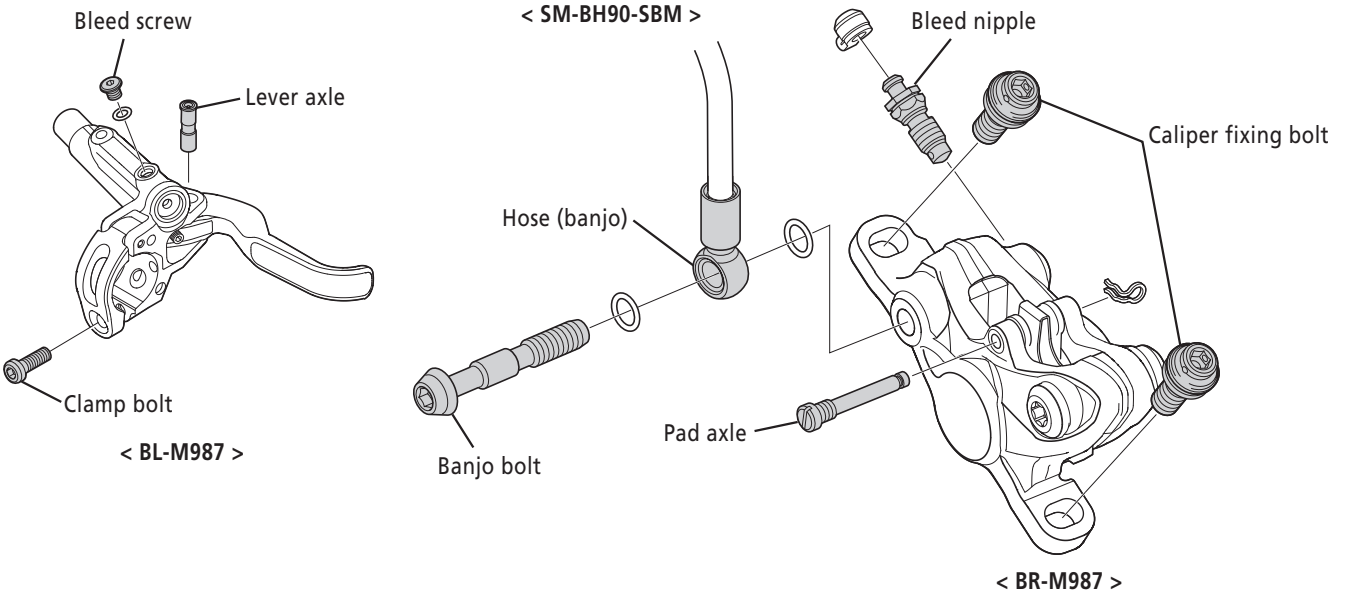

For customers who use this product with SM-MA90-F180P/P

When using BR-M987 with SM-MA90-F180P/P, be sure to use a surface-treated (silver) R washer. Do not use non-surface-treated (gray) R washers.

* R washers for S-part No. ISMMA90F180PP (SM-MA90-F180P/P) and S-part No. ESMMAF180PP2 (SM-MA-F180P/P2) are non-surface-treated (gray). Do not use them.

(R washers for S-part No. ISMMA90F180PPC and Shimano code No. Y8LF12000 (SM-MA90-F180P/P) are surface-treated (silver) and therefore usable.)

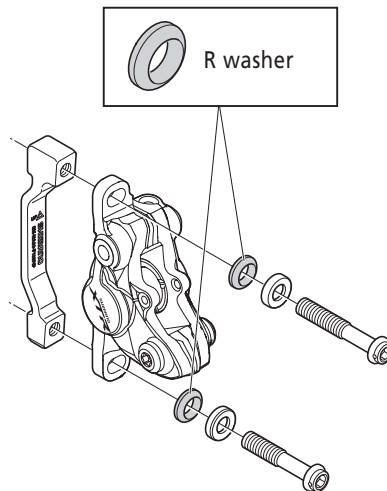

	S-part#	Surface-treatment for R washers	Use
SM-MA90-F180P/P	ISMMA90F180PPC	Silver	OK
	ISMMA90F180PP	Gray	Not OK
SM-MA-F180P/P2	ESMMAF180PP2	Gray	Not OK

Service parts (R washer)

ITEM No.	SHIMANO CODE No.	DESCRIPTION	Surface-treatment for R washers	Use
28	Y8LF12000	R-Washer A	Silver	OK

SHIMANO

SHIMANO AMERICAN CORPORATION

One Holland, Irvine, California 92618, U.S.A. Phone: +1-949-951-5003

SHIMANO EUROPE B.V.

Industrieweg 24, 8071 CT Nunspeet, The Netherlands Phone: +31-341-272222

SHIMANO INC.

3-77 Oimatsu-cho, Sakai-ku, Sakai-shi, Osaka 590-8577, Japan

Please note: specifications are subject to change for improvement without notice. (English)

© Oct. 2013 by Shimano Inc. HTR