



SALSA PRO MOTO STEM INSTRUCTIONS

At Salsa, we believe that a sense of adventure makes life better. The bicycle can be so much more than just a bike; it's a path to new places, new people, and amazing experiences.

Thank you for your purchase. We hope it makes a good riding experience even better!

Salsa. Adventure by bike.

▲ WARNING: CYCLING CAN BE DANGEROUS. BICYCLE PRODUCTS SHOULD BE INSTALLED AND SERVICED BY A PROFESSIONAL MECHANIC. NEVER MODIFY YOUR BICYCLE OR ACCESSORIES. READ AND FOLLOW ALL PRODUCT INSTRUCTIONS AND WARNINGS INCLUDING INFORMATION ON THE MANUFACTURER'S WEBSITE. INSPECT YOUR BICYCLE BEFORE EVERY RIDE. ALWAYS WEAR A HELMET.

Intended Use

SALSA STEMS ARE NOT INTENDED for hardcore freeriding, extreme downhill, dirt jumping, slopestyle, or very aggressive or extreme riding. No spending time in the air landing hard and hammering through obstacles.

Compatibility

▲ WARNING: This stem is only intended to be used with 1-1/8" threadless system forks—IT WILL NOT WORK with any other size. Threaded steerers have a reduced wall thickness and cannot be used with a threadless stem. Installing a threadless stem onto a threaded steerer can result in steerer failure and, consequently, serious injury or death to the rider.

All Salsa stems are designed for handlebars with a 31.8mm clamp diameter.

Tools

- 4mm hex wrench
- 5mm hex wrench
- Torque wrench

NOTE: Before removing your old stem and handlebar, and assuming the old position on the bike was a good one, note the angle of the bars and the position of the brake levers and shifters to replicate it as much as possible.

NOTE: If the old stem has a removable face plate, component removal is not necessary...just unbolt the face plate and remove the handlebar. If the old stem does not have a removable face plate, remove the components from one side of the handlebar and loosen the handlebar binder bolt(s) on the stem. Remove the old stem from the steerer while holding onto the fork, so the fork does not fall onto the floor or your foot. If you have a non-removable face plate type stem, now loosen the handlebar clamp bolt and carefully remove the handlebar.

▲ WARNING: A scratch or gouge in a handlebar can compromise its structural integrity and may cause failure.

NOTE: Before the stem installation, make sure the headset is properly installed and in good condition. The steerer clamp-to-steerer and handlebar clamp-to-handlebar mating surfaces must be clean and free of any dirt, lubricants and/or retaining compounds

Installation Of Threadless Stems

1. Install the fork and headset according to the instructions given by the manufacturer's of those products.
2. Any cable hanger and/or desired spacers should be installed first. Slide the stem onto the steerer.
3. Push the stem on the steerer as far as it will go, make sure everything is seated properly, and then tighten one binder bolt just enough to temporarily secure the stem to the steerer.
4. The top of the steerer should be 2-3mm below the top of the stem steerer clamp (fig. 1). If the steerer is too long with the desired amount of spacers inserted, it must be cut and the headset star-nut or compression plug must be repositioned. If the steerer is too short, there is insufficient clamping surface for the stem to be installed securely.

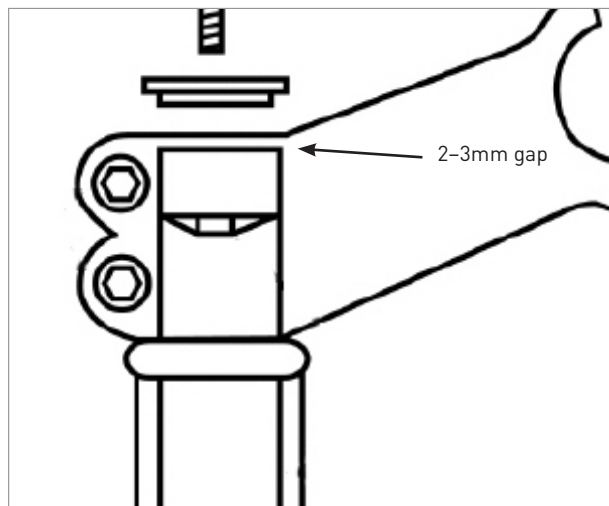

Figure 1

▲ WARNING: Installation of a stem onto a steerer that is too short may result in steerer or stem failure, resulting in rider injury or death.

5. Lubricate the top cap anchor bolt with grease. Place the top cap into the top of the stem, and insert the anchor bolt.
6. Thread the bolt into the star-nut or compression plug as far as it will go, but do not tighten yet.



SALSA PRO MOTO STEM INSTRUCTIONS

7. Now remove the binder bolts and lubricate them with grease. Reinstall them loosely but do not tighten them yet. Preload the headset by tightening the top cap anchor bolt to the torque specified by the headset manufacturer. Adjust preload until no binding or play (looseness) are present in the headset. Align the stem with the front wheel and now tighten the steerer clamp binder bolts alternately, to the recommended torque listed on the stem.
8. Once again, check for headset play. If play exists, loosen the steerer clamp pinch bolts and tighten the top cap anchor bolt 1/16th of a turn. Align the stem, and retighten the pinch bolts to the recommended torque listed on the stem.
9. Repeat until proper adjustment is made.
10. Remove and lubricate the handlebar clamp bolt threads with grease. Inspect the stem and handlebar clamping area for any burrs. Lightly clamp the handlebar face plate onto center of the handlebar, inserting and tightening both bolts just enough to hold the bar. Center and rotate the handlebar to the desired position. Alternately tighten the bolts working from the upper left, to the lower right, to the upper right, to the lower left in half-turn increments until they reach an equal reading of 5-8Nm (fig. 2). The upper and lower gaps between the front cap and the rear portion of the handlebar clamp should be equal. Install the components onto the handlebar, if necessary.
11. Install the components onto the handlebar, if necessary.

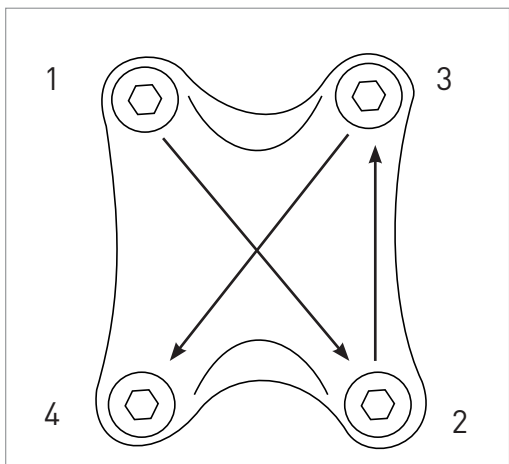

Figure 2

Ongoing Maintenance

Periodically check to make sure the stem bolts for the steerer tube clamp and stem faceplate are properly torqued to the indicated specification.

SALSA CYCLES

6400 West 105th Street, Bloomington, MN 55438
Tel: 877-MOTO-ACE Fax: 952-983-6210
www.salsacycles.com

Three-Year Warranty

All Salsa bicycle forks, parts and components.

This warranty applies to 2014 and newer model bicycles and covers only Salsa Cycles branded product. Any other original part or component shall be covered by the stated warranty of the original manufacturer. Any products not specifically included above are hereby omitted.

TO THE EXTENT NOT PROHIBITED BY LAW, THESE WARRANTIES ARE EXCLUSIVE AND THERE ARE NO OTHER EXPRESS OR IMPLIED WARRANTIES OR CONDITIONS INCLUDING WARRANTIES OR CONDITIONS OF MERCHANTABILITY AND FITNESS FOR A PARTICULAR PURPOSE.

For 2013 and older model bicycles and products, please consult your Owner's Manual or contact Salsa Cycles or your Salsa dealer for the applicable warranty information.

This warranty does not cover the following:

- Damage due to improper assembly or follow-up maintenance or lack of skill, competence or experience of the user or assembler
- Products that have been modified, neglected, used in competition or for commercial purposes, misused or abused, involved in accidents or anything other than normal use
- Installation of components, parts, or accessories not originally intended for use with or compatible with Salsa product
- Damage or deterioration to the surface finish, aesthetics or appearance of the product including but not limited to paint damage
- Normal wear and tear
- Labor required to remove and/or refit and re-adjust the product within the bicycle assembly
- Damage to carbon fiber caused by any carbon assembly paste

This limited warranty is expressly limited to the repair or replacement of a defective product, at the option of Salsa Cycles, and is the sole remedy of the warranty. This limited warranty applies only to the original purchaser of the Salsa Cycles product and is not transferable. This warranty applies only to Salsa Cycles products purchased through an authorized dealer or distributor. In no event shall Salsa Cycles be liable for any loss, inconvenience or damage, whether direct, incidental, consequential, or otherwise resulting from breach of any express or implied warranty or condition, of merchantability, fitness for a particular purpose, or otherwise with respect to our products except as set forth herein. This warranty gives the consumer specific legal rights, and those rights and other rights may vary from place to place. This warranty does not affect your statutory rights.