



Bluto & Reba 2017



Service Manual



SRAM LLC WARRANTY

EXTENT OF LIMITED WARRANTY

Except as otherwise set forth herein, SRAM warrants its products to be free from defects in materials or workmanship for a period of two years after original purchase. This warranty only applies to the original owner and is not transferable. Claims under this warranty must be made through the retailer where the bicycle or the SRAM component was purchased. Original proof of purchase is required. Except as described herein, SRAM makes no other warranties, guaranties, or representations of any type (express or implied), and all warranties (including any implied warranties of reasonable care, merchantability, or fitness for a particular purpose) are hereby disclaimed.

LOCAL LAW

This warranty statement gives the customer specific legal rights. The customer may also have other rights which vary from state to state (USA), from province to province (Canada), and from country to country elsewhere in the world.

To the extent that this warranty statement is inconsistent with the local law, this warranty shall be deemed modified to be consistent with such law, under such local law, certain disclaimers and limitations of this warranty statement may apply to the customer. For example, some states in the United States of America, as well as some governments outside of the United States (including provinces in Canada) may:

- a. Preclude the disclaimers and limitations of this warranty statement from limiting the statutory rights of the consumer (e.g. United Kingdom).
- b. Otherwise restrict the ability of a manufacturer to enforce such disclaimers or limitations.

For Australian customers:

This SRAM limited warranty is provided in Australia by SRAM LLC, 1000 W. Fulton Market, 4th Floor, Chicago, IL, 60607, USA. To make a warranty claim please contact the retailer from whom you purchased this SRAM product. Alternatively, you may make a claim by contacting SRAM Australia, 6 Marco Court, Rowville 3178, Australia. For valid claims SRAM will, at its option, either repair or replace your SRAM product. Any expenses incurred in making the warranty claim are your responsibility. The benefits given by this warranty are additional to other rights and remedies that you may have under laws relating to our products. Our goods come with guarantees that cannot be excluded under the Australian Consumer Law. You are entitled to a replacement or refund for a major failure and for compensation for any other reasonably foreseeable loss or damage. You are also entitled to have the goods repaired or replaced if the goods fail to be of acceptable quality and the failure does not amount to a major failure.

LIMITATIONS OF LIABILITY

To the extent allowed by local law, except for the obligations specifically set forth in this warranty statement, in no event shall SRAM or its third party suppliers be liable for direct, indirect, special, incidental, or consequential damages.

LIMITATIONS OF WARRANTY

This warranty does not apply to products that have been incorrectly installed and/or adjusted according to the respective SRAM user manual. The SRAM user manuals can be found online at sram.com, rockshox.com, avidbike.com, truvativ.com, or zipp.com.

This warranty does not apply to damage to the product caused by a crash, impact, abuse of the product, non-compliance with manufacturers specifications of usage or any other circumstances in which the product has been subjected to forces or loads beyond its design.

This warranty does not apply when the product has been modified, including, but not limited to any attempt to open or repair any electronic and electronic related components, including the motor, controller, battery packs, wiring harnesses, switches, and chargers.

This warranty does not apply when the serial number or production code has been deliberately altered, defaced or removed.

This warranty does not apply to normal wear and tear. Wear and tear parts are subject to damage as a result of normal use, failure to service according to SRAM recommendations and/or riding or installation in conditions or applications other than recommended.

Wear and tear parts are identified as:

- | | | | |
|---|--|--------------------------|----------------------|
| • Dust seals | • Stripped threads/bolts (aluminium, titanium, magnesium or steel) | • Handlebar grips | • Transmission gears |
| • Bushings | • Brake sleeves | • Shifter grips | • Spokes |
| • Air sealing o-rings | • Brake pads | • Jockey wheels | • Free hubs |
| • Glide rings | • Chains | • Disc brake rotors | • Aero bar pads |
| • Rubber moving parts | • Sprockets | • Wheel braking surfaces | • Corrosion |
| • Foam rings | • Cassettes | • Bottomout pads | • Tools |
| • Rear shock mounting hardware and main seals | • Shifter and brake cables (inner and outer) | • Bearings | • Motors |
| • Upper tubes (stanchions) | | • Bearing races | • Batteries |
| | | • Pawls | |

Notwithstanding anything else set forth herein, the battery pack and charger warranty does not include damage from power surges, use of improper charger, improper maintenance, or such other misuse.

This warranty shall not cover damages caused by the use of parts of different manufacturers.

This warranty shall not cover damages caused by the use of parts that are not compatible, suitable and/or authorised by SRAM for use with SRAM components.

This warranty shall not cover damages resulting from commercial (rental) use.

Table of Contents

Exploded View- Bluto & Reba	6
Record Your Settings.....	7
Service Interval Information	7
Torque Chart.....	7
Fluid Volume	7
RockShox® Suspension Service.....	8
Parts and Tools Needed for Service.....	8
Lower Leg Removal.....	9
Lower Leg Seal Service	11
Solo Air™ Spring Service.....	13
Travel Change Adjustment - Optional.....	13
Air Spring Removal.....	13
Solo Air Bottomless Token™ Installation	17
Air Spring Installation	18
Damper Service	20
Compression Damper Removal	20
Rebound Damper Removal	23
Rebound Damper Installation	25
Compression Damper Installation.....	27
Lower Leg Assembly.....	29



SAFETY FIRST!

We care about YOU. Please, always wear your safety glasses and protective gloves when servicing RockShox® products.

Protect yourself! Wear your safety gear!

Exploded View - Bluto & Reba

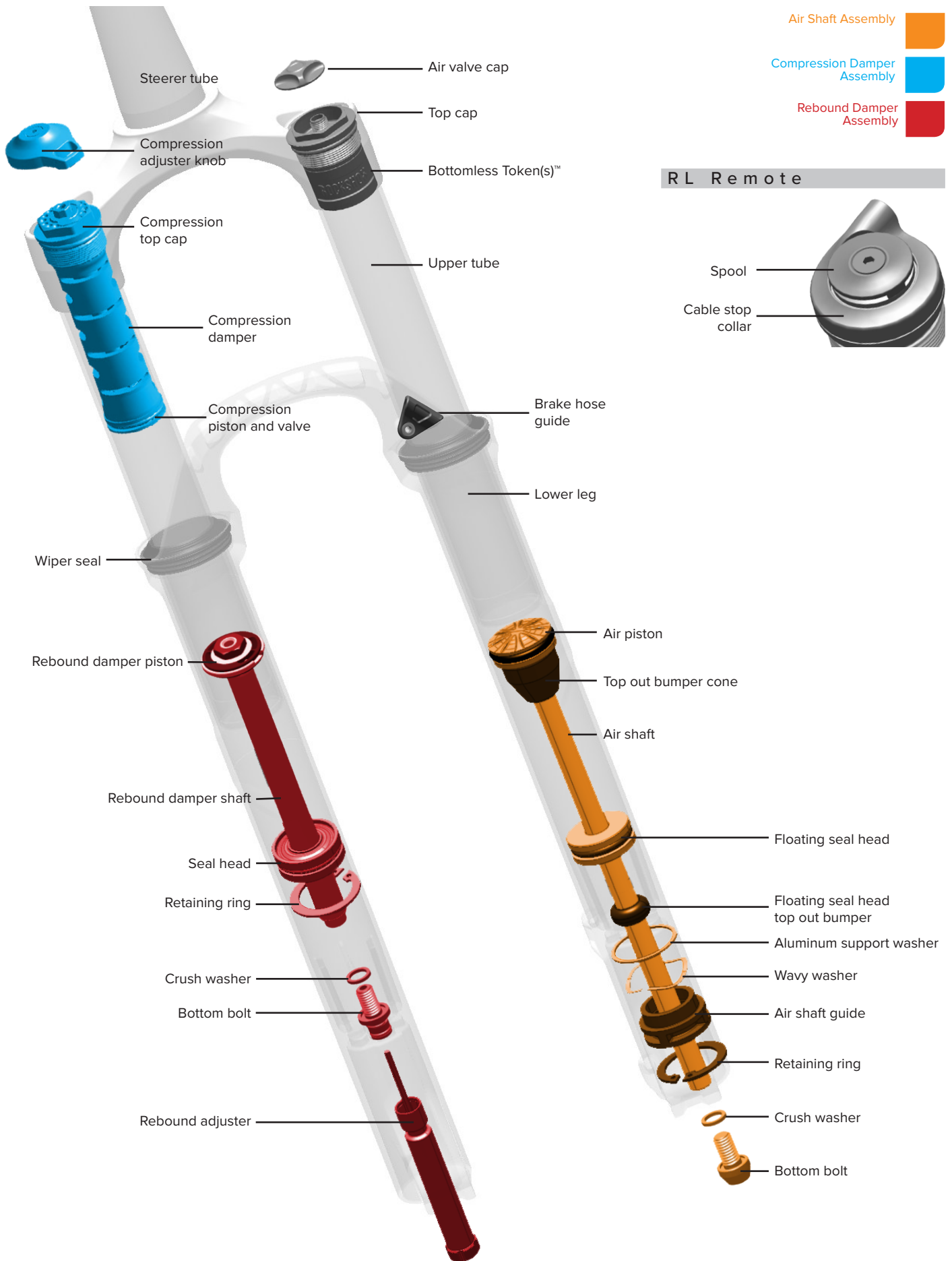

Record Your Settings

Use the charts below to record your fork settings to return your fork to its pre-service settings.

Service date - helps you keep track of service intervals.	
Air pressure - use a shock pump to determine how much air pressure is in your air spring.	
Rebound setting - count the number of clicks while turning the rebound adjuster fully counter-clockwise.	
Compression setting - count the number of clicks while turning the compression adjuster fully counter-clockwise.	

Service Interval Information

Maintenance	Interval
Clean dirt and debris from upper tubes	Every ride
Check air pressure	Every ride
Inspect upper tubes for scratches	Every ride
Check front suspension fasteners for proper torque	25 hours
Remove lowers, clean/inspect bushings and change fluid bath	50 hours
Clean and lubricate air shaft assembly	100 hours
Change fluid in damping system	100 hours

Torque Chart

Part	Tool	Torque
Bottom bolts	5 mm hex bit socket	7.3 N•m (65 in-lb)
Bottomless Tokens™	8 mm hex bit socket and 24 mm socket	3.4-4.5 N•m (30-40 in-lb)
Cable pinch bolt	2 mm hex bit socket	0.9 N•m (8 in-lb)
Top caps	24 mm socket	12.4 N•m (110 in-lb)
Cable stop collar	2 mm hex bit socket	1.4 N•m (12 in-lb)
Gate adjuster knob screw	1.5 mm hex bit socket	0.6 N•m (5 in-lb)
Compression adjuster screw	2.5 mm hex bit socket	1.4 N•m (12 in-lb)

Fluid Volume

Fork	Model	Damper						Spring					
		Damper Technology	Upper Tube			Lower Leg		Spring Technology	Upper Tube		Lower Leg		
			Volume	Height	Fluid	Volume	Fluid		Volume	Fluid	Volume	Fluid	
Reba	RL	Motion Control	106 mL	71-77 mm	5wt	5 mL	15wt	Solo Air	Grease		5 mL	15wt	
	RL3		111 mL	64-70 mm									
Bluto	RL	Motion Control	106 mL	71-77 mm	5wt	5 mL	15wt	Solo Air	Grease		5 mL	15wt	
	RCT3												

RockShox® Suspension Service

We recommend that you have your RockShox suspension serviced by a qualified bicycle mechanic. Servicing RockShox suspension requires knowledge of suspension components as well as the special tools and fluids used for service.

For exploded diagram and part number information, please refer to the Spare Parts Catalog available on our website at sram.com/service. For order information, please contact your local SRAM® distributor or dealer.

Information contained in this publication is subject to change at any time without prior notice. For the latest technical information, please visit our website at sram.com/service.

Your product's appearance may differ from the pictures contained in this publication.

Parts and Tools Needed for Service

Parts

- RockShox Reba or Bluto Service Kit
- Optional travel change solo air spring assembly

Safety and Protection Supplies

- Safety glasses
- Nitrile gloves
- Apron
- Clean, lint-free rags
- Oil pan

RockShox Tools

- RockShox shock pump (300 psi max)
- 32 mm seal installation tool (Reba)
- 32 mm flangeless seal installation tool (Bluto)

Lubricants and Fluids

- Isopropyl alcohol
- RockShox 15wt suspension fluid
- RockShox 5wt suspension fluid
- Liquid-O-Ring® PM600 military grease (Reba)
- SRAM® Butter grease (required for Bluto)

Common Tools

- 1.5, 2, 2.5, and 5 mm hex wrench
- 1.5, 2, 2.5, and 5 mm hex bit socket
- 10 mm open end wrench
- 24 mm socket wrench
- Flat blade screwdriver
- Torque wrench
- Pick
- Plastic mallet
- Schrader valve core tool
- Large internal retaining ring pliers
- Long plastic or wooden dowel
- Syringe

Bicycle Tools

- Bicycle work stand
- Downhill tire lever

SAFETY INSTRUCTIONS

Always wear safety glasses and nitrile gloves when working with suspension fluid and bicycle grease.

Place an oil pan on the floor underneath the area where you will be working on the fork.

NOTICE

Before you begin service, clean the exterior of the product to prevent contamination of internal parts.

Do not scratch parts when you remove o-rings or seals that form a seal. Inspect each part for scratches before you complete service. Scratches can cause leaks which can reduce product performance.

Spray isopropyl alcohol on each part and clean with a rag. Apply grease to the new seal or o-ring.

Use SRAM® Butter when servicing Bluto forks. Use SRAM Butter or Liquid O-Ring® PM600 military grease when servicing Reba forks.

Install crowfoot sockets at 90 degrees to the torque wrench to ensure an accurate torque value.



Lower Leg Removal

- 1 Remove the air valve cap from the top cap located on the spring side fork leg.



- 2 Use a small hex wrench to depress the Schrader valve and release all air pressure from the air chamber.

Use a Schrader valve core tool to remove the valve core from the valve body. Cycle the lower leg a few times to release the remaining trapped air. Install a new Schrader valve core.

⚠ CAUTION- EYE HAZARD

Verify all pressure is removed from the fork before proceeding. Failure to do so can result in injury and/or damage to the fork. Wear safety glasses.



Small hex wrench

- 3 Remove the rebound adjuster knob by pulling it from the bottom bolt at the bottom of the damper side fork leg.



- 4 Use a 5 mm hex wrench to loosen the both bottom bolts 3 to 4 turns.



5 mm

Loosen 3 to 4 turns

- 5** Place an oil pan beneath the fork to catch any draining fluid.
- Insert a 5 mm hex wrench into the damper side bottom bolt. Use a plastic mallet to firmly strike the wrench to dislodge the damper shaft from the lower leg.
- Insert a 5 mm hex wrench into the spring side bottom bolt. Use a plastic mallet to firmly strike the wrench to dislodge the air shaft from the lower leg.
- Use a 5 mm hex wrench to remove the bottom bolts from the lower leg.



- 6** Firmly pull the lower leg downward until fluid begins to drain. Continue pulling downward to remove the lower leg from the fork.
- If the lower leg does not slide off of the upper tube or if fluid does not drain from either side, the press fit of the shaft(s) to the lower leg may still be engaged. Reinstall the bottom bolts 2 to 3 turns and repeat the previous step.*

NOTICE

Do not hit the fork arch with any tool when removing the lower leg as this could damage the fork.

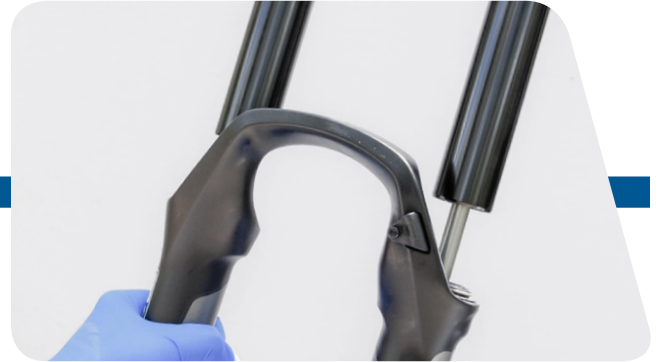

- 7** Spray isopropyl alcohol on the inside and outside of the lower leg and clean it with a rag.
- Wrap a rag around a long dowel and insert it into each lower leg to clean the inside.



Lower Leg Seal Service

- 1 Stabilize the lower leg on a bench top or on the floor. Place the tip of a downhill tire lever under the dust wiper seal. Press down on the downhill tire lever handle to remove the seal.

Repeat on the other side. Discard the wiper seals.

NOTICE

Keep the lower leg stable. Do not allow the lower leg to twist in opposite directions, compress toward each other, or be pulled apart. This will damage the lower leg.



Downhill tire lever

- 2 Use your fingers to remove and discard the foam rings on the top bushing inside the lower leg.

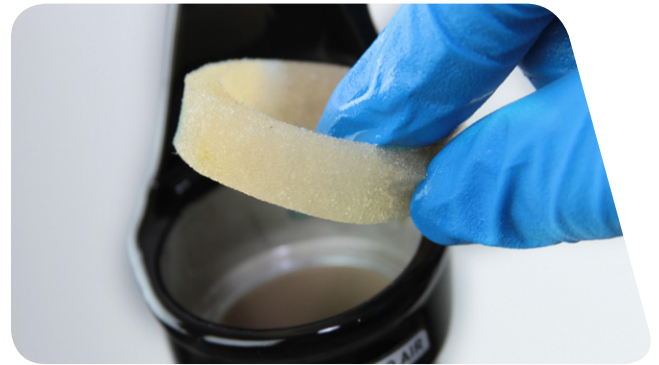

- 3 Spray isopropyl alcohol on the inside and outside of the lower leg and clean it with a rag.

Wrap a rag around a long dowel and insert it into each lower leg to clean the inside.



- 4 Soak the new foam rings in RockShox® 15wt suspension fluid. Install a new foam ring on each top bushing in the lower leg.

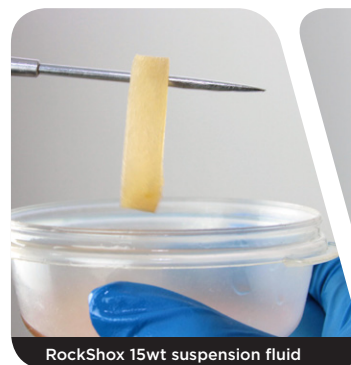

RockShox 15wt suspension fluid



- 5** Remove the wire spring from the new wiper seal and set the spring aside.
Insert the narrow end of a wiper seal into the recessed end of the seal installation tool.

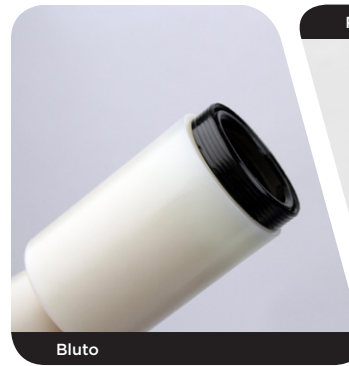

- 6** Hold the lower leg firmly and use the seal installation tool to push the wiper seal evenly into the lower leg until the seal surface is flush with the top of the lower leg surface.

Reinstall the wire spring onto the wiper seal.

Repeat on the other side.

NOTICE

Only press the wiper seal into the lower leg until it is flush with the top surface of the lower leg. Pressing the wiper seal past the top surface of the lower leg can damage the foam rings.

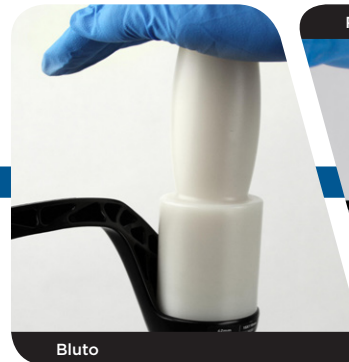

Travel Change Adjustment - Optional

To change the travel in your suspension fork, use the chart below to determine the air shaft length and recommended number of Bottomless Tokens™ for your wheel size.

To increase or decrease the travel in your Bluto or Reba fork, the air spring must be replaced with the correct length air spring shaft assembly. For example, to change a 27.5" Reba with 80 mm of travel to 100 mm of travel, a 202.2 mm air spring shaft assembly must be installed. Fork travel and size can be identified at the bottom of the air spring shaft.

Bottomless Tokens can be added to, or removed from, the air top cap to fine-tune the bottomout feel and spring curve. Use the chart below to help determine the number of Bottomless Tokens that can be used with each maximum fork travel option. If fork travel is changed from stock, it may be necessary to add or remove Bottomless Tokens to the air top cap assembly.

Refer to the RockShox® Spare Parts Catalog available on our website at sram.com/service for spare part kit details. For part ordering information, please contact your local SRAM distributor or dealer.

Desired Travel	Recommended Bottomless Tokens™ (4 maximum)	Required Solo Air Spring Assembly Length for 26" wheel	Required Solo Air Spring Assembly Length for 27.5" and 29" wheel
80 mm	4	147.2 mm	182.2 mm
90 mm	3	157.2 mm	192.2 mm
100 mm	2	167.2 mm	202.2 mm
110 mm	1	177.2 mm	212.2 mm
120 mm	0	187.2 mm	222.2 mm

Air Spring Removal

NOTICE

Do not scratch parts when you remove o-rings or seals that form a seal. Inspect each part for scratches before you complete service. Scratches can cause leaks which can reduce product performance.

Spray isopropyl alcohol on each part and clean with a rag. Apply grease to the new seal or o-ring.

Use SRAM® Butter when servicing Bluto forks. Use SRAM Butter or Liquid O-Ring® PM600 military grease when servicing Reba forks.

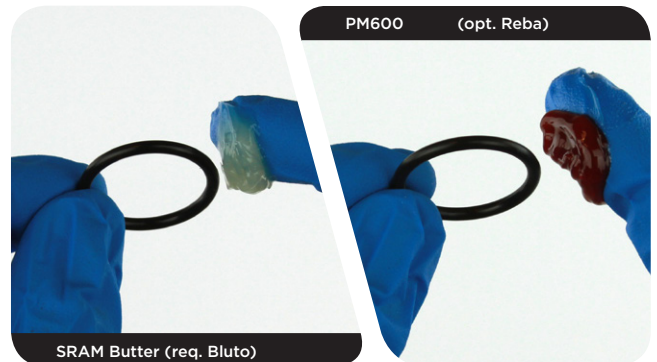

- 1 Use a small hex wrench to depress the Schrader valve and verify all air pressure is removed from the air chamber.

⚠ CAUTION- EYE HAZARD

Verify all pressure is removed from the fork before proceeding. Failure to do so can cause the top cap to eject forcefully from the upper tube which can result in injury. Wear safety glasses.



2 Use a 24 mm socket wrench to remove the top cap from the spring side upper tube.

Spray isopropyl alcohol on the upper tube threads and clean the threads with a rag.



3 Use your fingers or a pick to remove the top cap o-ring.

Use your fingers to install a new o-ring.

Do not apply grease to the top cap threads.



4 Use a pick to remove and replace the air valve cap o-ring.



- 5** Use a flat blade screwdriver to push the seal head tab under the retaining ring. Push the air shaft in to prevent it from getting scratched by the retaining ring.

NOTICE

Scratches on the air shaft will allow air to bypass the seal head into the lower leg. Scratches can result in reduced spring performance.

Place the tips of large internal retaining ring pliers into the eyelets of the retaining ring. Press firmly on the pliers to push the solo air seal head into the upper tube enough to compress and remove the retaining ring. Slide the retaining ring onto your finger and release the air shaft.

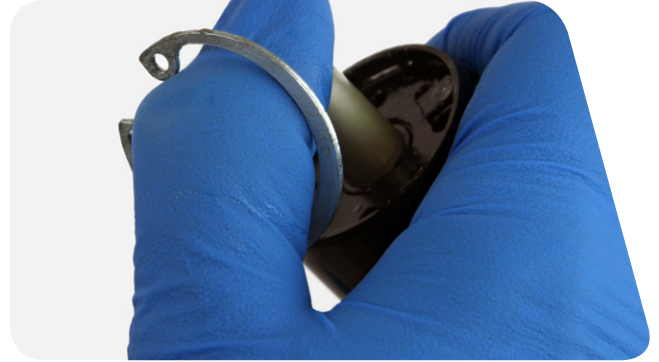
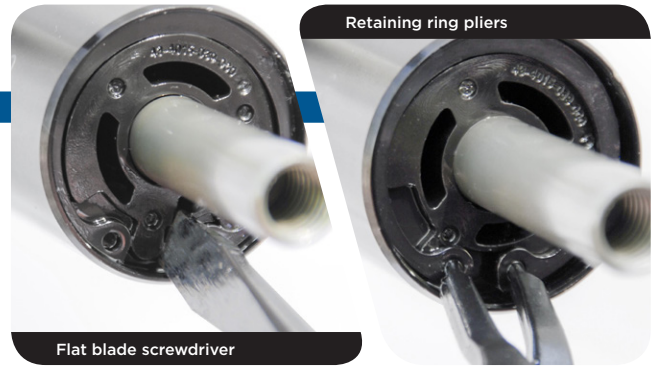

- 6** Firmly pull on the air shaft to remove the air shaft assembly from the upper tube.

Clean and inspect the assembly for damage.



- 7** Spray isopropyl alcohol on the inside and outside of the upper tube and clean it with a rag.

Wrap a rag around a long dowel and insert it into the upper tube to clean inside the upper tube.



- 8** Remove the seal head assembly from the air shaft.
Spray isopropyl alcohol on the air shaft and clean it with a rag.



- 9** Use your fingers or a pick to remove the outer floating seal head o-ring and inner seal head o-ring. Use your fingers to install the new o-rings.



- 10** Use your fingers or a pick to remove the air piston outer o-ring. Use your fingers to install a new o-ring.



- 11** Use your fingers or a pick to remove the top out bumper cone from the air piston.



Solo Air Bottomless Token™ Installation

Bottomless Tokens reduce the air volume in your fork to create greater ramp at the end of the fork travel. Add tokens to maintain your fork's bottomless feel. Consult the Bottomless Tokens user manual for the maximum number of tokens for your fork.

- 1 Thread a Bottomless Token into another token or into the the bottom of the top cap. Use an 8 mm hex wrench and a torque wrench with a 24 mm socket to tighten the token to 3.4-4.5 N•m (30-40 in-lb).



Air Spring Installation

- 1 Install a new top out bumper cone onto the air shaft so it covers the tension pin hole on the air piston.

NOTICE

If the tension pin is protruding or not centered, replace the air piston assembly.



- 2 Apply a liberal amount of grease to the inside of the upper tube, from the end of the tube to approximately 60 mm into the tube.

NOTICE

Only use SRAM® Butter grease on Bluto forks. Use Liquid O-Ring® PM600 military grease or SRAM Butter when servicing Reba forks. No other grease is approved for use.



- 3 Apply a liberal amount of grease to the air piston and top out bumper cone.

NOTICE

Only use SRAM Butter grease on Bluto forks. Use Liquid O-Ring PM600 military grease or SRAM Butter when servicing Reba forks. No other grease is approved for use.



- 4 Apply a liberal amount of grease 40-60 mm wide around the air shaft.

NOTICE

Only use SRAM Butter grease on Bluto forks. Use Liquid O-Ring PM600 military grease or SRAM Butter when servicing Reba forks. No other grease is approved for use.



- 5** Install the floating seal head, floating seal head top out bumper, aluminum support washer, wavy washer, and air shaft guide, in that order, onto the air shaft.

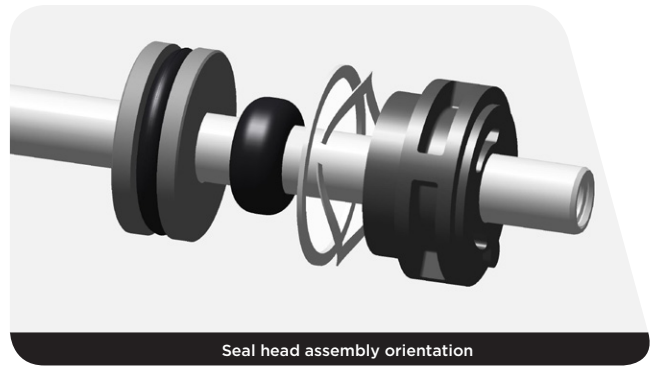

- 6** Push the air shaft and seal head assembly into the bottom of the upper tube while gently rocking the air shaft side to side.
- Orient the washers so that the aluminum support washer goes into the upper tube first, followed by the wavy washer.
- Use your fingers to firmly press the seal head into the upper tube until it snaps into place.



- 7** Push the air shaft into the upper tube to prevent it from getting scratched while installing the retaining ring.

NOTICE

Scratches on the air shaft will allow air to bypass the air shaft guide into the lower leg. Scratches can result in reduced spring performance.

Place the tips of large internal retaining ring pliers into the eyelets of the retaining ring and install the retaining ring into the groove. The tab of the air shaft guide should be positioned between the retaining ring eyelets.

Confirm the retaining ring is properly seated in the retaining ring groove. Firmly pull down on the air shaft.

Retaining rings have a sharper-edged side and a rounder-edged side. Install retaining rings with the sharper-edged side facing the tool to allow for easier installation and removal.



- 8** Install the top cap into the top of the spring side upper tube. Use a torque wrench with a 24 mm socket to tighten the top cap to 12.4 N•m (110 in-lb).



NOTICE

Before you begin service, clean the exterior of the product to prevent contamination of internal parts.

Do not scratch parts when you remove o-rings or seals that form a seal. Inspect each part for scratches before you complete service. Scratches can cause leaks which can reduce product performance.

Spray isopropyl alcohol on each part and clean with a rag. Apply grease to the new seal or o-ring.

Use SRAM® Butter when servicing Bluto forks. Use SRAM Butter or Liquid O-Ring® PM600 military grease when servicing Reba forks.

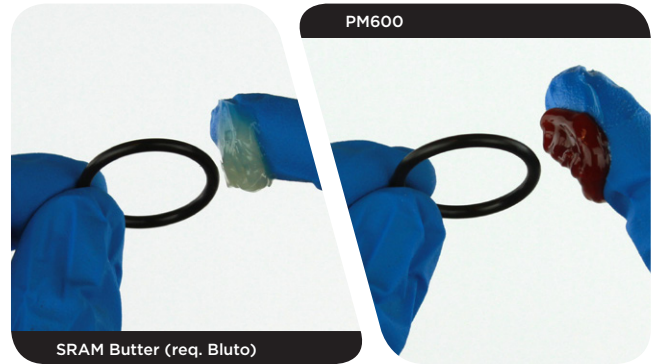

Compression Damper Removal

7 Rotate the compression adjuster knob to the open position.

RCT3: Use a 1.5 mm hex wrench to remove the low speed compression set screw.

Use a 10 mm open end wrench to remove the nut. Remove the compression adjuster knob.



RL: Use a 2.5 mm hex wrench to remove the compression adjuster knob retention screw. Remove the compression adjuster knob.



RL Remote: Press the remote lever in to the open position. Use a 2.5 mm hex wrench to loosen the compression adjuster knob retention screw. Remove the cable and cable spool from the top cap.

Use a 2 mm hex wrench to loosen the cable stop collar clamping bolt. Remove the cable stop collar.

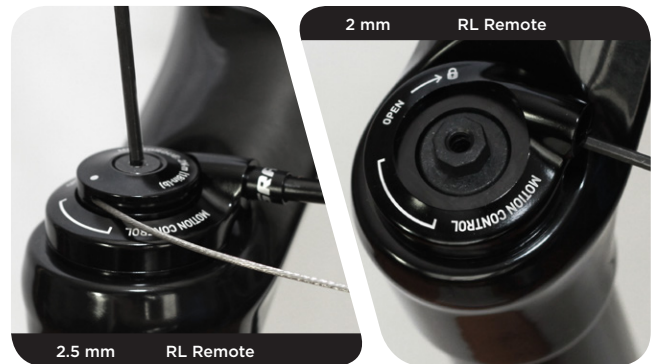

- 2** Use a 24 mm socket to loosen the compression damper top cap.
Remove the compression damper by pulling up and gently rocking side to side. Clean the upper tube threads with a rag.



- 3** Use a pick or your fingers to remove the compression top cap o-ring. Install a new compression top cap o-ring.



- 4** Use your fingers or a pick to remove the compression damper piston o-ring. Apply **suspension fluid** to the new o-ring and install it.

RCT3: Install a new glide ring on the compression damper piston.



5 Pour the suspension fluid into an oil pan.



Rebound Damper Removal

- 1 Push the rebound damper shaft in until enough shaft is exposed to hold onto with your fingers.
Use large internal retaining ring pliers to remove the retaining ring from the bottom of the damper side upper tube.

NOTICE

Do not let the retaining ring contact the shaft. Scratches on the shaft will allow fluid to bypass the seal head into the lower leg. Scratches can result in reduced damper performance.



- 2 Remove the rebound damper and seal head assembly from the upper tube.



- 3 Spray isopropyl alcohol on the inside and outside of the upper tube and clean it with a rag.
Wrap a rag around a long dowel and insert it into the upper tube to clean inside the upper tube.



- 4 Remove the seal head from the rebound damper shaft.
Spray isopropyl alcohol on the rebound damper shaft and clean it with a rag.

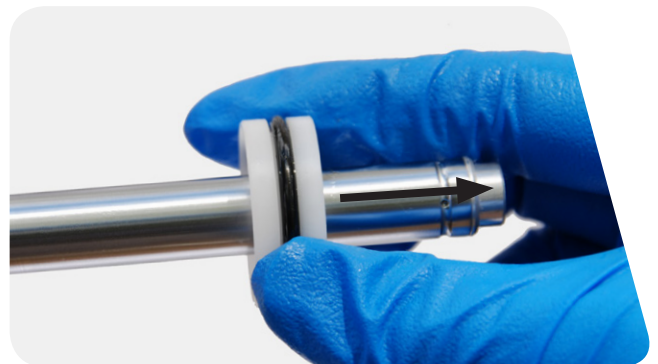

- 5** Use your fingers or a pick to remove the outer seal head o-ring. Use a pick to pierce and remove the rod wiper seal.

Apply **suspension fluid** to the new o-ring and rod wiper seal and install them on the seal head.



- 6** Use your fingers to remove the glide ring from the rebound damper piston. Use your fingers to install a new glide ring.



Rebound Damper Installation

1 Install the seal head on the rebound damper shaft.

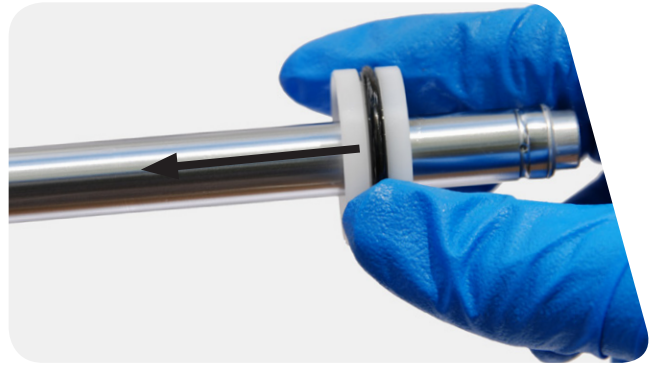

2 Insert the rebound damper piston into the bottom of the upper tube at an angle with the *side opposite the glide ring split entering first*. Continue to angle and rotate the piston until the glide ring is inside the upper tube.



3 Use your finger to push the seal head into the upper tube until the retaining ring groove is visible.

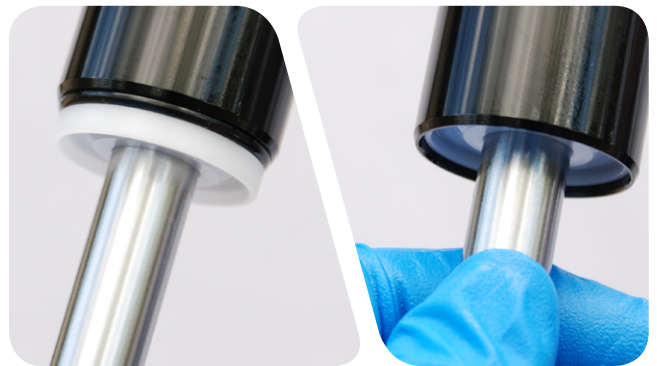

4 Push the rebound damper shaft into the upper tube to prevent it from getting scratched while installing the retaining ring.

NOTICE

Scratches on the rebound damper shaft will allow fluid to bypass the seal head into the lower leg. Scratches can result in reduced damper performance.

Place the tips of large internal retaining ring pliers into the eyelets of the retaining ring and install the retaining ring into the groove.

Confirm the retaining ring is properly seated in the retaining ring groove.

Retaining rings have a sharper-edged side and a rounder-edged side. Install retaining rings with the sharper-edged side facing the tool to allow for easier installation and removal.



5 Pull the rebound damper shaft down to the fully extended position.



6 Use the chart to determine the amount of RockShox® 5wt suspension fluid to pour in the damper side upper tube.

Fork	Model	Fluid Volume	Fluid Height
Bluto	RL and RCT3	106 mL	71-77 mm
Reba	RL		
Reba	RL3	111 mL	64-70 mm

Fluid height measurements are taken from the top of the crown surface above the upper tube to the fluid.

Suspension fluid volume is critical. Too much suspension fluid reduces available travel, too little suspension fluid decreases damping performance.



Compression Damper Installation

- 1 RL only:** Turn the compression valve at the bottom of the compression piston to the open position.
Insert the compression damper into the upper tube. Press down and rock side to side until the damper is installed.



- 2** Use a torque wrench with a 24 mm socket to tighten the compression top cap to 12.4 N·m (110 in-lb).



- 3 RCT3:** Install the compression adjuster knob on the compression top cap so the knob dial is against the hard stop.
Use a 10 mm open end wrench to tighten the washer bolt.
Use a torque wrench with a 1.5 mm hex bit socket to tighten the low speed compression set screw to 0.6 N·m (5 in-lb).



- RL:** Install the compression adjuster knob on the compression top cap so the knob dial is against the hard stop.
Use a torque wrench with a 2.5 mm hex bit socket to tighten the compression adjuster knob retention screw to 1.4 N·m (12 in-lb).



RL Remote: Install the cable stop collar on the compression top cap so the cable stop faces the front of the fork, perpendicular to the crown.

Use a torque wrench with a 2 mm hex bit socket to tighten the collar clamp bolt to 1.4 N·m (12 in-lb).

Install the bottom spool with the grooves up.



Install the cable spool top so the indicator dot on the cable spool is oriented within the bracket printed on the cable stop.

Seat the ferrule and cable housing into the remote counterbore and cable stop. Thread the cable through the cable spool. Pull the cable taut and use a torque wrench with a 2.5 mm hex bit socket to tighten the cable spool screw to the 2 N·m (18 in-lb).

Cut the excess cable, leaving 30 mm protruding from the cable fixing port. Install a cable end fitting.



Lower Leg Assembly

- 1 Spray isopropyl alcohol on the upper tubes and clean them with a rag.



- 2 Apply a liberal amount of SRAM® Butter to the inner surfaces of the wiper seals.

Wiper seals may already be greased from the factory. Do not apply extra grease to seals that already have grease on them.



- 3 Slide the lower leg onto the upper tube enough to engage the upper bushing with the upper tube.

NOTICE

Make sure both wiper seals slide onto the tubes without folding the outer lip of either seal.



- 4 Position the fork at a slight angle with the lower leg bolt holes oriented upward. Angle a syringe fitting in each lower leg bolt hole so the fluid will only contact the inside of the lower leg.

Inject 5 mL of RockShox® 15wt suspension fluid into the damper side lower leg, and 5 mL of RockShox 15wt suspension fluid into the spring side lower leg.

NOTICE

Do not exceed the recommended fluid volume per leg as this can damage the fork.



- 5** Slide the lower leg assembly along the upper tubes until it stops and the air shaft and damper shaft are visible through the lower leg bolt holes.



- 6** Install a new crush washer on the spring side and damper side bottom bolts.

NOTICE

Dirty or damaged crush washers can cause leaks.

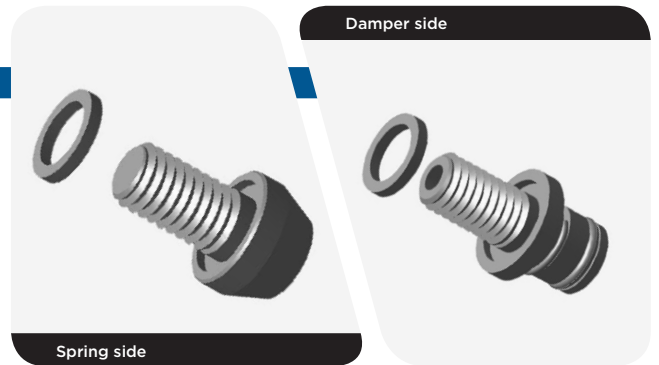

- 7** Thread the black bottom bolt into the spring side shaft of the lower leg. Thread the red bottom bolt into the damper side shaft of the lower leg. Use a torque wrench with a 5 mm hex bit socket to tighten the bolts to 7.3 N-m (65 in-lb).



- 8** Install the rebound damper knob into the drive side rebound damper bottom bolt until it is secure. Refer to your pre-service recorded rebound setting to adjust the rebound.

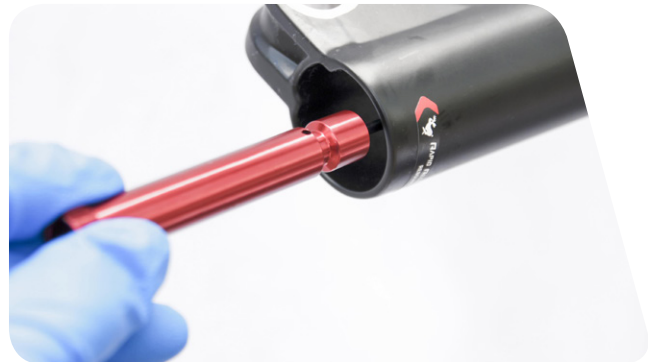

- 9** Refer to your pre-service recorded settings to pressurize your air spring, or use the air chart on the fork's lower leg and pressurize the air spring to the appropriate pressure for your rider weight.

You may see a drop in the indicated air pressure on the pump gauge while filling the air spring; this is normal. Continue to fill the air spring to the recommended air pressure.



- 10** Thread the air valve cap onto the top cap of the spring side fork leg until it stops.



- 11** Spray isopropyl alcohol on the entire fork and clean it with a rag.

This concludes the service of your RockShox Bluto & Reba suspension fork.

For remote service, please visit [sram.com/service](https://www.sram.com/service).

This publication includes trademarks and registered trademarks of the following company:

Liquid-O-Ring® is a registered trade name of Oil Center Research, Inc.

SRAM[®]

www.sram.com

“We will revolutionize the relationship that our users have with SRAM products, cultivating a bond between the rider and bicycle. Our technical communication will be delivered in innovative and exciting ways, with deliberation and accuracy that inspires loyalty and trust across the globe.”

-SRAM TechCom Vision Statement



ASIAN HEADQUARTERS
SRAM Taiwan
No. 1598-8 Chung Shan Road
Shen Kang Hsiang, Taichung City
Taiwan R.O.C.

WORLD HEADQUARTERS
SRAM LLC
1000 W. Fulton Market, 4th Floor
Chicago, Illinois 60607
USA

EUROPEAN HEADQUARTERS
SRAM Europe
Paasbosweg 14-16
3862ZS Nijkerk
The Netherlands