

# 2009



**POWERED BY SRAM**

# SRAM CORPORATION WARRANTY

## EXTENT OF LIMITED WARRANTY

SRAM warrants its products to be free from defects in materials or workmanship for a period of two years after original purchase. This warranty only applies to the original owner and is not transferable. Claims under this warranty must be made through the retailer where the bicycle or the SRAM component was purchased. Original proof of purchase is required.

## LOCAL LAW

This warranty statement gives the customer specific legal rights. The customer may also have other rights which vary from state to state (USA), from province to province (Canada), and from country to country elsewhere in the world.

To the extent that this warranty statement is inconsistent with the local law, this warranty shall be deemed modified to be consistent with such law, under such local law, certain disclaimers and limitations of this warranty statement may apply to the customer. For example, some states in the United States of America, as well as some governments outside of the United States (including provinces in Canada) may:

- a. Preclude the disclaimers and limitations of this warranty statement from limiting the statutory rights of the consumer (e.g. United Kingdom).
- b. Otherwise restrict the ability of a manufacturer to enforce such disclaimers or limitations.

## LIMITATIONS OF LIABILITY

To the extent allowed by local law, except for the obligations specifically set forth in this warranty statement, In no event shall SRAM or its third-party suppliers be liable for direct, indirect, special, incidental, or consequential damages.

## LIMITATIONS OF WARRANTY

- This warranty does not apply to products that have been incorrectly installed and/or adjusted according to the respective SRAM technical installation manual. The SRAM user manuals can be found online at [www.sram.com](http://www.sram.com), [www.rockshox.com](http://www.rockshox.com) or [www.avidbike.com](http://www.avidbike.com).
- This warranty does not apply when the product has been modified.
- This warranty does not apply when the serial number or production code has been deliberately altered, defaced or removed.
- This warranty does not apply to damage to the product caused by a crash, impact, abuse of the product, non-compliance with manufacturer's specifications of usage or any other circumstances in which the product has been subjected to forces or loads beyond its design.
- This warranty does not apply to normal wear and tear. Wear and tear parts are subject to damage as a result of normal use, failure to service according to SRAM recommendations and/or riding or installation in conditions or applications other than recommended.

## EXAMPLES OF WEAR AND TEAR:

Dust seals/Bushings/Air sealing o-rings/Glide rings/Rubber moving parts/Foam rings/Rear shock mounting hardware and main seals/Stripped threads and bolts (aluminum,titanium, magnesium or steel)/Upper tubes (stanchions)/Brake sleeves/Brake pads/Chains/Sprockets/Cassettes/Shifter and brake cables (inner and outer)/Handlebar grips/Shifter grips/Jockey wheels/Disc brake rotors/Wheel braking surfaces/Bottomout pads/Bearings/Pawls/Transmission gears/Tools

- This warranty shall not cover damages caused by the use of parts of different manufacturers.
- This warranty shall not cover damages caused by the use of parts that are not compatible, suitable and/or authorized by SRAM for use with SRAM components.
- This warranty shall not cover damages resulting from commercial (rental) use.

# AVID BRAKE SERVICE

We recommend that you have your Avid brakes serviced by a qualified bicycle mechanic. Servicing Avid brakes requires knowledge of brakes components as well as the special tools and fluids used for service.

Used brake fluid should be recycled or disposed of in accordance to local and federal regulations.

NEVER pour brake fluid down a sewage or drainage system or into the ground or a body of water.

# TABLE OF CONTENTS

<b>GETTING STARTED</b> .....	<b>5</b>
BRAKE STYLE & SERVICE CATEGORIES.....	6
TOOLS NEEDED FOR SERVICE.....	7
<b>HYDRAULIC DISC BRAKELEVER OVERHAUL</b> .....	<b>9</b>
ELIXIR R, CR.....	10
CODE 5 - JUICY 3, 5, 7, CARBON, ULTIMATE .....	13
CODE.....	19
<b>DISC BRAKECALIPER OVERHAUL</b> .....	<b>25</b>
ELIXIR R, CR.....	26
JUICY 3, 5, 7, CARBON.....	29
JUICY ULTIMATE.....	32
CODE, CODE 5.....	36
BB7 MOUNTAIN & ROAD .....	40
<b>HYDRAULIC DISC BRAKEHOSE LENGTH ADJUSTMENT &amp; BLEED</b> .....	<b>45</b>
ELIXIR R, CR - JUICY 3, 5, 7, CARBON, ULTIMATE - CODE, CODE 5 .....	46
<b>DISC BRAKEPAD REPLACEMENT</b> .....	<b>53</b>
ELIXIR R, CR.....	54
JUICY 3, 5, 7, CARBON, ULTIMATE .....	55
CODE, CODE 5.....	56
BB7 MOUNTAIN & ROAD .....	57



# SAFETY FIRST!

At SRAM Corporation, we care about YOU. Please, ALWAYS wear your safety glasses when servicing your Avid brakes. Protect your eyes! Wear your safety glasses!

# GETTING STARTED

---

## GETTING STARTED - HELPFUL HINTS

The Avid Technical Manual assumes you are performing a complete overhaul of the entire braking system and separates brake service into four main service categories:

1. hydraulic disc brake lever overhaul
2. disc brake caliper overhaul
3. hydraulic disc brake hose length adjustment & bleeding
4. disc brake pad replacement

You will need to know what style of brakes you have in order to service successfully service them. Some brakes do not use all four service categories . If you are unsure of the style of your brakes, contact your local Avid dealer for assistance.

# BRAKE STYLE & SERVICE CATEGORIES

## (ALL BRAKES)

The following chart lists the serviceable brake models in the 2009 Avid product line. It details each brake model style and the corresponding service categories.

**Important:** You must bleed your brakes if you overhaul the levers and/or the calipers on a hydraulic disc brake system. Overhauling the levers and/or calipers introduces small amounts of air into the system. Failure to bleed the brakes to remove this air can degrade the performance of your brakes, which could lead to serious and/or fatal injury while riding.

BRAKE MODELS	BRAKE STYLE		SERVICE CATEGORIES			
	HYDRAULIC DISC	MECHANICAL DISC	LEVER OVERHAUL	CALIPER OVERHAUL	HOSE ADJUST & BLEED	PAD REPLACEMENT
ELIXIR R, CR	X		X	X	X	X
JUICY 3, 5, 7, CARBON, ULTIMATE	X		X	X	X	X
CODE, CODE 5	X		X	X	X	X
BB7 (Mountain and Road)		X		X		X

# TOOLS NEEDED FOR SERVICE

## (ALL BRAKES)

The following chart is a list of the tools needed to service on your 2009 model year Avid brakes. While this chart is intended to be comprehensive, it is still only a guide. The tools required for each step of service are detailed in the text of each service section. Keep in mind your specific brakes may not require every tool listed.

TOOLS	LEVER OVERHAUL	CALIPER OVERHAUL	HOSE ADJUST & BLEED	PAD REPLACEMENT
<b>SAFETY/STARTING EQUIPMENT</b>				
SAFETY GLASSES	X	X	X	X
APRON	X	X	X	X
RUBBER GLOVES	X	X	X	X
CLEAN RAGS (LINT FREE)	X	X	X	X
OIL PAN	X	X	X	X
CLEAN WORK AREA	X	X	X	X
<b>WRENCHES/PLIERS</b>				
2.5 MM HEX	X		X	
4 MM HEX		X	X	X
T-8 TORX	X			
T-10 TORX	X	X		
T-30 TORX		X		
8 MM OPEN END OR BOX WRENCH		X		
11 MM OPEN END OR BOX WRENCH		X		
TORQUE WRENCH			X	
NEEDLE-NOSED PLIERS	X	X		X
SNAP RING PLIERS - INTERNAL	X	X		
E-CLIP TOOL (OPTIONAL)	X			
<b>MISC TOOLS/KITS</b>				
AVID BLEED KIT	X	X	X	
HYDRAULIC LINE CUTTERS OR VERY SHARP HOUSING CUTTERS			X	
SHARP PICK	X	X	X	
ISOPROPYL ALCOHOL			X	
SMALL AND LARGE FLATHEAD SCREWDRIVERS	X	X		X
PHILLIPS HEAD SCREWDRIVER	X			
AIR COMPRESSOR WITH BLOW GUN CHUCK		X		
SOAPY WATER	X	X	X	
ICE COLD BEVERAGE	X	X	X	X





# **HYDRAULIC DISC BRAKE LEVER OVERHAUL**

# ELIXIR R, CR

## INTRODUCTION

Avid brake lever assemblies need to be serviced in order to optimize braking function. If brake fluid is leaking from any area of the brake lever assembly, there may be damage or wear and tear to the internal moving parts. If your brake was filled with fluid OTHER than DOT 4 or 5.1, damage to all rubber and plastic internal parts may exist. If your brake was damaged in a crash, there may be damage to the lever blade and pushrod assemblies, as well as the housing assembly. Inspection and/or replacement of these parts, due to any of the above situations, will be necessary to restore proper brake function.

## LEVER OVERHAUL SERVICE INSTRUCTIONS

### GETTING STARTED

1. Remove brake lever from handlebar. Remove caliper from fork or frame. If dirty, clean with soapy water and a clean rag. Pull hose boot off compression nut and slide down hose (not pictured).
2. Elixir CR: Use an 11 mm open ended wrench to hold the hose stop in place and use an 8 mm open ended wrench to unscrew the hose compression nut.  
Elixir R: Use an 8 mm open ended wrench to unscrew the hose compression nut.

2



3



Unthread the compression nut completely by hand and slide it down the hose. Pull brake hose and compression fitting from lever body.

3. Allow any brake fluid to drain into a container. Hold lever assembly over container and pump lever to remove any brake fluid inside lever assembly.

**NOTE: IF THE SYSTEM HAS BEEN CONTAMINATED WITH THE WRONG FLUID, YOU WILL NEED TO FLUSH ALL THE PARTS WITH SOAPY WATER AND ALLOW TO DRY FULLY PRIOR TO REBUILDING. YOU WILL ALSO NEED TO INSTALL A NEW HOSE.**

### LEVER ASSEMBLY

Take a few moments and familiarize yourself with the internal components of your brake lever. This will assist you in identifying the components while you service your brake.

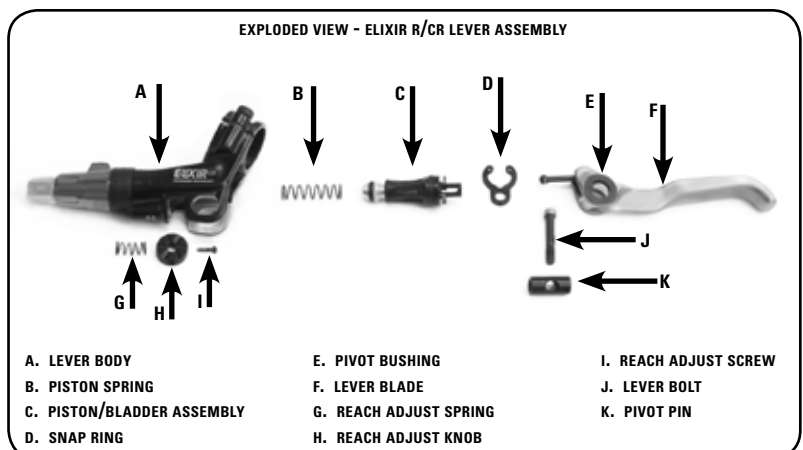

## LEVER OVERHAUL SERVICE INSTRUCTIONS (CONT)

### REMOVE LEVER

4. Use a small phillips screwdriver and remove the screw from the reach adjust knob.
5. Use a 3 mm hex and remove the lever bolt.
6. Carefully pull and remove the reach adjust knob and attached spring.

**IMPORTANT: POINT THE REACH ADJUST KNOB AWAY FROM YOUR EYES WHEN REMOVING. THE SPRING IS PRE-LOADED AND MAY POP OUT SUDDENLY WITH THE KNOB.**

7. Pull back on the lever to fully open and disengage the push rod from the piston. Use a small hex wrench to push the pivot pin out of the lever. Pull straight back on the lever blade and remove.

**NOTE: THE PIVOT BUSHINGS MAY FALL OUT OF THE LEVER BLADE, THIS IS OK. SIMPLY RE-INSERT THEM INTO THE LEVER BLADE.**

8. Use long snap ring pliers and remove the snap ring in the lever body along with the piston/bladder assembly.

**NOTE: THE PISTON/BLADDER ASSEMBLY IS ATTACHED TO THE SNAP RING.**

9. Inspect the bladder for damage. If damaged replace the entire piston/bladder and snap ring assembly.

10. Remove the piston spring. Use a pick to remove and replace both the piston glide ring and o-ring. Do NOT re-install the piston spring at this time.

**IMPORTANT: BE CAREFUL NOT TO DAMAGE THE PISTON GLAND WITH THE PICK.**

**IMPORTANT: DO NOT RE-INSTALL THE PISTON SPRING AT THIS TIME.**

11. Lubricate the piston/bladder assembly by dipping it into DOT 5.1 fluid and allow the excess fluid to drip off.

**TIP: YOU CAN ALSO USE DOT COMPATIBLE GREASE AS A LUBRICANT.**

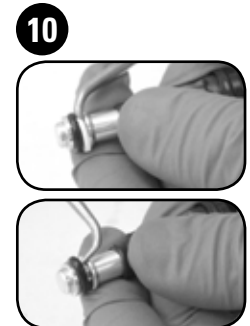
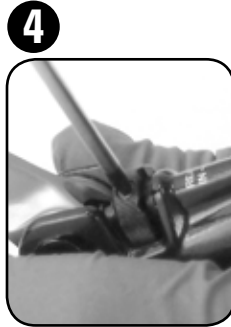

## LEVER OVERHAUL SERVICE INSTRUCTIONS (CONT)

### LEVER INSTALLATION

12. Use long snap ring pliers and re-install the piston/bladder assembly into the lever body.
13. Slide lever blade and push rod assembly straight into lever body until you hear an audible click indicating the push rod is fully seated in the piston.
14. Align the hole in lever blade with the slot in lever body and re-install the pivot pin so it sits flush.

**IMPORTANT: MAKE SURE THE PIVOT BUSHINGS ARE INSTALLED.**

15. Slide the reach adjust bolt through the pivot pin hole and slide the piston spring over the bolt.
16. Place the reach adjust knob onto the spring, compress the spring, and slide the reach adjust knob into place in the lever body.
17. Use a 3 mm hex to thread the lever bolt so the slot in the bolt is aligned with the hole in the knob.
18. Use a small phillips screwdriver and re-install the screw for the reach adjust knob. Tighten until snug.

**THIS CONCLUDES THE LEVER OVERHAUL SERVICE INSTRUCTIONS. YOU HAVE DONE A GREAT JOB AND ARE READY TO MOVE ON TO THE NEXT CHAPTER, HYDRAULIC DISC BRAKE CALIPER OVERHAUL. ENJOY!**

12



13



14



15



16



17



18



# CODE 5 - JUICY 3, 5, 7, CARBON, ULTIMATE

## INTRODUCTION

Avid brake lever assemblies need to be serviced in order to optimize braking function. If brake fluid is leaking from any area of the brake lever assembly, there may be damage or wear and tear to the internal moving parts. If your brake was filled with fluid OTHER than DOT 4 or 5.1, damage to all rubber and plastic internal parts may exist. If your brake was damaged in a crash, there may be damage to the lever blade and pushrod assemblies, as well as the reservoir cap, bladder and star wheel assemblies. Inspection and/or replacement of these parts, due to any of the above situations, will be necessary to restore proper brake function.

## LEVER OVERHAUL SERVICE INSTRUCTIONS

### GETTING STARTED

1. Remove brake lever from handlebar. Remove caliper from fork or frame. If dirty, clean with soapy water and a clean rag. Pull hose boot off compression nut and slide down hose (not pictured).
2. Using an 8 mm (or 5/16" line wrench) and socket wrench, loosen and remove compression nut from lever body. Turn counterclockwise to remove. Unthread completely by hand and slide compression nut down hose. Pull brake hose and compression fitting from lever body.
3. Allow any brake fluid to drain into a container. Hold lever assembly over container and pump lever to remove any brake fluid inside lever assembly.

**NOTE: IF THE SYSTEM HAS BEEN CONTAMINATED WITH THE WRONG FLUID, YOU WILL NEED TO FLUSH ALL THE PARTS WITH SOAPY WATER AND ALLOW TO DRY FULLY PRIOR TO REBUILDING. YOU WILL ALSO NEED TO INSTALL A NEW HOSE.**

### RESERVOIR COVER/BLADDER REMOVAL

4. Using a T-10 Torx (small Phillips screwdriver for Juicy 3), remove both reservoir cover screws.
5. Remove reservoir cover cap and bladder from lever assembly. Additional brake fluid will drain from lever. Hold lever over container and allow fluid to drain. Set lever assembly down on clean towel (not pictured).
6. Holding the reservoir cover, remove bladder from reservoir cover. Replace with new bladder if contaminated and leaking fluid.

**NOTE: POSSIBLE CAUSES OF LEAKING BLADDER AND/OR RESERVOIR INCLUDE: BRAKE SYSTEM MAY HAVE TOO MUCH FLUID, BLADDER MAY HAVE SPLIT, AND/OR BLADDER MAY BE CONTAMINATED.**

2



3



4



6



## LEVER OVERHAUL SERVICE INSTRUCTIONS (CONT)

### RESERVOIR COVER/BLADDER INSTALLATION

7. Insert new bladder into cover and seat flush into underside of reservoir cover. Make sure you have the correct orientation.
8. Place reservoir cover and bladder back onto lever body. Install and tighten cover cap screws (short screw closest to lever clamp). Tighten both screws with a T-10 Torx (small Phillips head screwdriver for Juicy 3).

7



8



9



### BLEED SCREWS REMOVAL

9. Use a T-10 Torx wrench to remove both bleed screws.
10. Using a sharp pick, remove both o-rings on bleed screws and replace.
11. Install bleed screws back into lever body.  
**NOTE: FOR JUICY 3, 5 PLEASE MOVE ON TO THE LEVER BLADE/PUSHROD REMOVAL PROCEDURES.**

10



11



12



### STAR WHEEL AND WORM REMOVAL JUICY 7, CARBON, & ULTIMATE ONLY

12. Remove retaining e-clip with sharp pick or small flathead screwdriver.
13. Juicy 7, Carbon Only:  
Unthread star wheel and worm from lever body. Unthread by hand; pull out to remove from lever assembly.  
**OR**  
Juicy Ultimate Only:  
Unthread worm from lever body using a 2.5 mm hex.

13



OR



14. Using a pick, insert into gear hole, and push bushing out of lever body. Set star wheel/ worm assembly aside.

**NOTE: DO NOT RE-INSTALL STAR WHEEL AND WORM GEAR BACK INTO LEVER ASSEMBLY AT THIS POINT.**

**IMPORTANT: REPLACE THE STAR WHEEL AND WORM GEAR IF IT IS DAMAGED, CRACKED OR BROKEN, OR IF YOU ARE SWITCHING SIDES OF LEVER BODY OR ROTATING BRAKE LEVER TO OTHER SIDE OF BAR.**

14



15



16



### LEVER BLADE/PUSHROD REMOVAL

15. Code 5, Juicy 5, 7, Carbon, Ultimate Only:  
Holding the lever in both hands, place your thumbs near the pivot and push. The lever gently snaps into the open position.
16. Using a 2.5mm hex wrench (T-8 Torx for Juicy Carbon/Ultimate), unthread lever pivot set screw and remove completely.
17. Using a small hex wrench, push lever pivot pin through lever body and remove.

17



## LEVER OVERHAUL SERVICE INSTRUCTIONS (CONT)

### LEVER BLADE/PUSHROD REMOVAL (CONT)

18. Juicy 3 Only: Use a 2mm hex wrench and unthread the lever pushrod completely by turning clockwise. Pull lever blade away from lever body.

OR

Code 5, Juicy 5, 7, Carbon, Ultimate Only: Pull lever blade away from lever body and remove pushrod pin from worm gear. It will pop out. Remove pushrod from lever. Replace pushrod dust boot if damaged. Clean if not damaged. Insert pushrod dust boot back onto pushrod with the open end facing the pin and the closed end toward threads. Re-install pushrod into lever blade. Pushrod unthreads and threads back into lever blade (not pictured).

**IMPORTANT: REPLACE LEVER BLADE AND/OR PUSHROD IF EITHER IS BENT OR DAMAGED.**

### INTERNALS REMOVAL

Take a few moments and familiarize yourself with the internal components of your brake lever. This will assist you in identifying the components while you service your brake.

18



OR

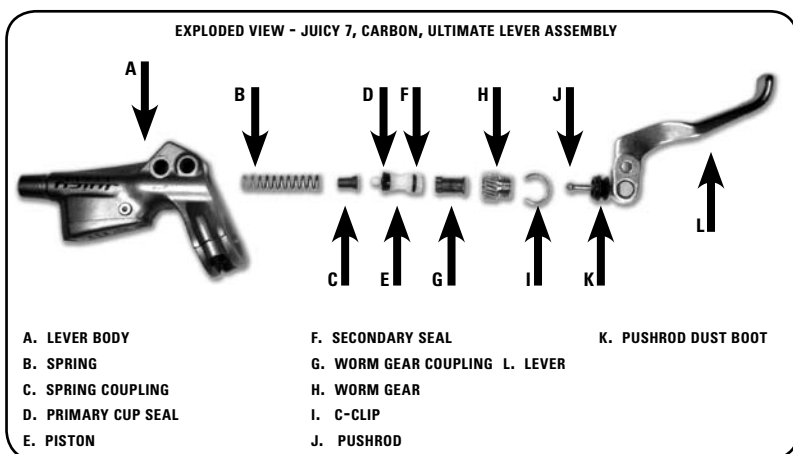
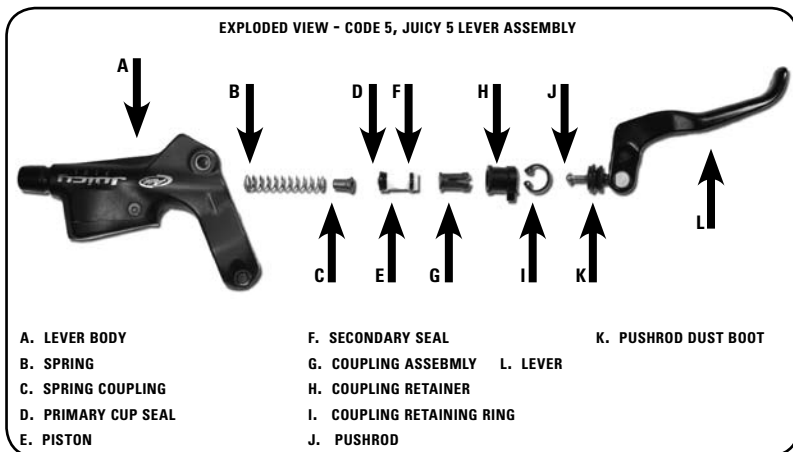
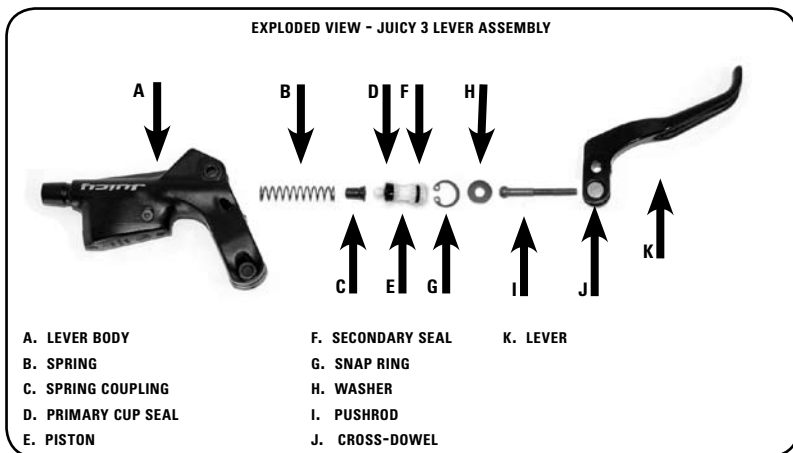

## LEVER OVERHAUL SERVICE INSTRUCTIONS (CONT)

### INTERNALS REMOVAL

19. Code 5, Juicy 3, 5 Only: Using straight internal snap ring pliers, remove coupling retaining ring. Pull retaining ring from inside the lever body. **IMPORTANT: PULL RETAINING RING OUT SLOWLY. THE COUPLING RETAINER/COUPLING ASSEMBLY MAY 'POP' OUT WITH THE FORCE OF THE SPRINGS. DO NOT LOOK INSIDE WHILE REMOVING TO AVOID POTENTIAL EYE DAMAGE.** Using needle-nosed pliers, carefully remove coupling retainer/coupling assembly. Coupling retainer should slide out from lever body easily. Hold lever body assembly upside down and drop the piston/spring assembly into your hand. It should slide out easily.

19



OR

OR

- Juicy 7, Carbon, Ultimate Only: Rotate worm gear retaining clip with a small flathead screwdriver or sharp pick until the end of the clip protrudes past the gap in the lever body (push end of clip to rotate within groove). Using needle-nosed pliers, grasp the clip to remove from the lever body. Insert a large flathead screwdriver into wide slot in top of worm gear and turn counterclockwise. Unthread worm gear completely and slide/pull worm gear out of lever body assembly. Worm gear coupling is located inside worm gear. The piston spring (below piston inside lever body) should force piston assembly out of lever body. If the spring does not aid piston removal, use a sharp hooked pick to pull piston and spring assembly from lever body. Be careful not to damage the piston. **NOTE: IF THE WORM GEAR COUPLING IS CRACKED, PULL COUPLING OUT OF GEAR AND REPLACE. COUPLING CAN WEAR OUT OVER TIME AND CRACK.**



20



21



20. With piston/spring assembly removed from lever body, remove the piston from the spring.  
 21. Using a small flathead screwdriver, remove spring coupling from piston. Do not scratch any plastic parts (piston or o-rings). If damaged, you will need to replace the piston  
 22. Slide piston coupling out of piston (not pictured).  
 23. Remove and replace piston secondary seal (small o-ring) on top of piston.

23





## LEVER OVERHAUL SERVICE INSTRUCTIONS (CONT)

### INTERNALS REMOVAL (CONT)

24. Remove primary cup seal (lower large black seal) from piston with sharp pick and slide new coupling seal onto base of piston. Ensure it sits flush (flat end first, flush against piston, open end out).
25. Re-install spring coupling back onto piston and coupling seal (into open end of seal).
26. Re-install spring onto coupling. The coupling lightly snaps onto piston.

24



25



26



### INTERNALS INSTALLATION

27. Insert spring/piston assembly back into lever body, spring first.
28. Code 5, Juicy 5 Only: Insert coupling retainer and coupling assembly onto top of piston, inside lever body. The v-shape of the retainer should be positioned in the lever blade groove. Using straight internal snap ring pliers, insert coupling retaining ring above coupling retainer and into groove in lever body. Ensure retaining ring snaps into place securely.

27



28



CODE 5, JUICY 5

CODE 5, JUICY 5

OR

Juicy 7, Carbon, Ultimate Only: Slide worm gear coupling (geared end first) into narrow end of worm gear. The coupling slides directly into inner worm gear threads.

Insert worm gear and coupling assembly onto top of piston, inside lever body.

Insert large flathead screwdriver into open end (flat slot) of worm gear. Turn clockwise to thread worm gear into lever body. Press down into worm gear while the gear threads into lever body. You will feel spring resistance as you turn. Worm gear threads will engage the threads in lever body.

Turn clockwise until worm gear is completely inside lever body, then back off three turns. This is the correct installation setting.

Using needle-nosed pliers, insert worm gear retaining clip above worm gear. Position one end of clip into groove and slowly but firmly push down on clip with pliers until clip snaps firmly into place in groove. Rotate clip until ends are inside of groove.

**IMPORTANT: ENDS OF CLIP MUST NOT PROTRUDE PAST LEVER BODY GROOVE OR EXTEND INTO LEVER SLOT/GAP IN LEVER BODY.**

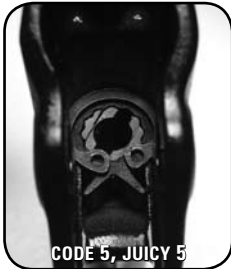

CODE 5, JUICY 5

OR



JUICY 7, CARBON,  
ULTIMATE



JUICY 7, CARBON,  
ULTIMATE



JUICY 7, CARBON,  
ULTIMATE



JUICY 7, CARBON,  
ULTIMATE



JUICY 7, CARBON,  
ULTIMATE

## LEVER OVERHAUL SERVICE INSTRUCTIONS (CONT)

### LEVER/PUSHROD INSTALLATION

29. Juicy 3 Only: Place washer onto pushrod. Insert pushrod and washer into lever body so that pushrod sets on top of the piston. Using straight internal snap ring pliers, push retaining ring into lever body so that piston is compressed and retaining ring snaps into place. This holds piston assembly and pushrod inside lever body. Line up pushrod with the threaded hole in the cross-dowel of the lever. Using 2mm hex, thread the pushrod completely by turning counter-clockwise.

OR

Code 5, Juicy 5 Only: Line up pushrod pin with slot in coupling retainer. Insert pushrod pin into coupling retainer. Pushrod pin snaps into slot.

OR

Juicy 7, Carbon, Ultimate Only: Line up pushrod pin with slot in worm gear coupling (wide slot in center of worm gear coupling). Insert pushrod into worm gear coupling. Pushrod pin snaps into worm gear inner coupling slot.

30. Insert s into lever body; one on each side. The bushing lip (larger end) should be on inside of lever body.
31. Line up lever pivot pin hole with bushing holes. Insert pivot pin back into lever and bushings. Use your thumb to press down on pivot pin and snap it into place.
32. Install the pivot pin set screw into the lever blade and tighten with a 2.5mm hex wrench
- NOTE: THIS CONCLUDES THE LEVER OVERHAUL SERVICE INSTRUCTIONS FOR CODE 5, JUICY 3, 5. PLEASE MOVE ON TO STEP 37, FINISHING UP PROCEDURES.**

### STAR WHEEL AND WORM INSTALLATION - JUICY 7, CARBON, ULTIMATE ONLY.

**NOTE: JUICY ULTIMATE IS NOT EQUIPPED WITH A STAR WHEEL KNOB, HOWEVER, THE PROCEDURE IS SIMILAR.**

33. Juicy 7, Carbon Only: Press star wheel/worm bushing back into lever body with thumb. Thread star wheel/worm assembly back into lever body.

OR

Juicy Ultimate Only: Press bushing back into lever body with thumb. Using a 2.5mm hex, thread onto worm.

34. Using a pair of needle-nosed pliers or a retaining clip tool, press the retaining clip onto end of worm to secure lever assembly.

### FINISHING UP

35. Clean the entire lever assembly with soapy water and clean rag (not pictured). **THIS CONCLUDES THE LEVER OVERHAUL SERVICE INSTRUCTIONS. YOU HAVE DONE A GREAT JOB AND ARE READY TO MOVE ON TO THE NEXT CHAPTER, HYDRAULIC DISC BRAKE CALIPER OVERHAUL. ENJOY!**

29

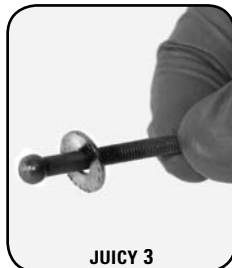

JUICY 3

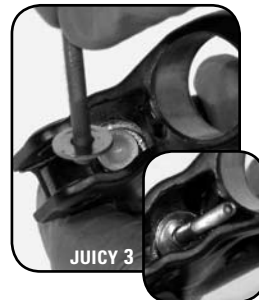

JUICY 3



JUICY 3



JUICY 3

OR



CODE 5, JUICY 5

30

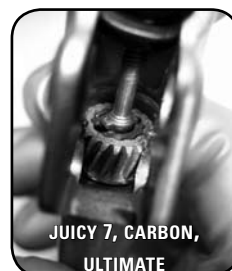

JUICY 7, CARBON,  
ULTIMATE



OR

31



32



33



JUICY 7, CARBON

34



JUICY ULTIMATE



OR

# CODE

## INTRODUCTION

Avid brake lever assemblies need to be serviced in order to optimize braking function. If brake fluid is leaking from any area of the brake lever assembly, there may be damage or wear-n-tear to the internal moving parts. If your brake was filled with fluid OTHER than DOT 4 or 5.1, damage to all rubber and plastic internal parts may exist. If your brake was damaged in a crash, there may be damage to the lever blade and pushrod assemblies, as well as the reservoir cap, bladder and star wheel assemblies. Inspection and/or replacement of these parts, due to any of the above situations, will be necessary to restore proper brake function.

## CODE LEVER OVERHAUL SERVICE INSTRUCTIONS

### GETTING STARTED

1. Remove brake lever from handlebar. Remove caliper from fork or frame. If dirty, clean with soapy water and a clean rag. Pull hose boot off compression nut and slide down hose (not pictured).
2. Using an 8mm crow's-foot (included in Avid Bleed Kit) and socket wrench (or use a flare nut 8mm wrench), loosen and remove compression nut from lever body. Turn counterclockwise to remove. Unthread completely by hand and slide compression nut down hose. Pull brake hose and compression fitting from lever body.
3. Allow any brake fluid to drain into a container. Hold lever assembly over container and pump lever to remove any brake fluid inside lever assembly.

**NOTE: IF THE SYSTEM HAS BEEN CONTAMINATED WITH THE WRONG FLUID, YOU WILL NEED TO FLUSH ALL THE PARTS WITH SOAPY WATER AND ALLOW TO DRY FULLY PRIOR TO REBUILDING. YOU WILL ALSO NEED TO INSTALL A NEW HOSE.**

### RESERVOIR COVER/BLADDER REMOVAL

4. Using a T-10 Torx wrench, remove the reservoir cover screws.
5. Remove reservoir cover cap and bladder from lever assembly. Additional brake fluid will drain from lever. Hold lever over container and allow fluid to drain. Set lever assembly down on clean towel (not pictured).
6. Holding the reservoir cover, remove bladder from reservoir cover. Replace with new bladder if contaminated and leaking fluid.

**NOTE: POSSIBLE CAUSES OF LEAKING BLADDER AND/OR RESERVOIR INCLUDE: BRAKE SYSTEM MAY HAVE TOO MUCH FLUID, BLADDER MAY HAVE SPLIT, AND/OR BLADDER MAY BE CONTAMINATED.**

2



3



4



6



## LEVER OVERHAUL SERVICE INSTRUCTIONS (CONT)

### RESERVOIR COVER/BLADDER REMOVAL (CONT)

7. Insert new bladder into cover and seat flush into underside of reservoir cover. Make sure you have the correct orientation.

**NOTE: DO NOT RE-INSTALL RESERVOIR COVER AT THIS TIME.**

### BLEED SCREWS REMOVAL

8. Using a T-10 Torx wrench, remove both bleed screws.
9. Using a sharp pick, remove both o-rings on bleed screws and replace.
10. Install bleed screws back into lever body.

### LEVER BLADE/CAM REMOVAL

11. Using two 4mm hex wrenches, loosen and remove the lever pivot shoulder bolt and lever pivot sleeve bolt.
12. Rotate the lever and cam assembly toward the handlebar clamp. Carefully remove the lever blade and return spring from the cam.
13. Slide a hex wrench through the bearing in the cam and pull the gently pull the cam off the end of the pushrod.
14. Remove the pushrod coupling from the cam with needlenose pliers. If the pushrod coupling remains connected to the pushrod, pull it off with needlenose pliers.

### INTERNALS REMOVAL

Take a few moments and familiarize yourself with the internal components of your brake lever. This will assist you in identifying the components while you service your brake.

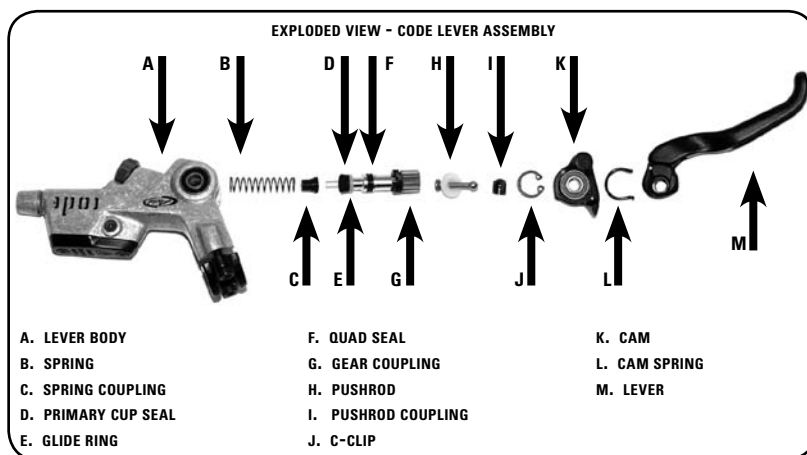
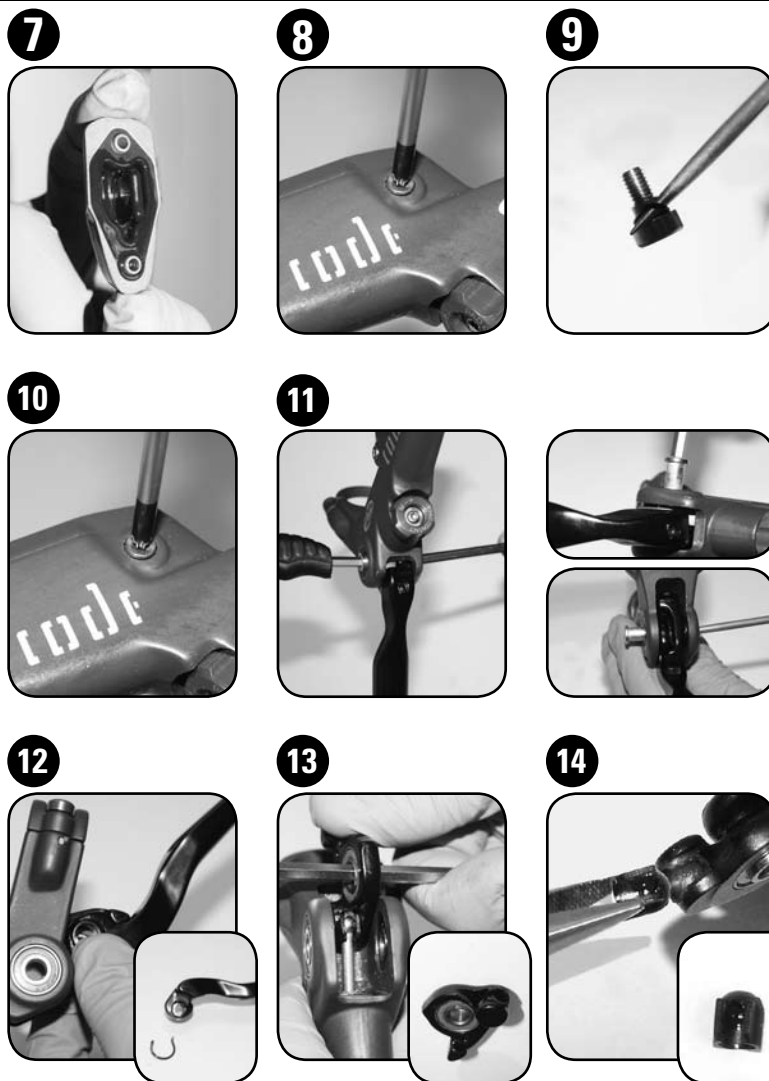

## LEVER OVERHAUL SERVICE INSTRUCTIONS (CONT)

### INTERNALS REMOVAL (CONT)

15. Using snap ring pliers, remove the retaining ring located in the lever body at the base of the push rod. Remove pushrod and internal piston/spring assembly.

**IMPORTANT: THE INTERNAL PISTON/SPRING ASSEMBLY IS PRELOADED AND WILL COME OUT OF THE LEVER BODY QUICKLY. BE SURE TO POINT THE ASSEMBLY IN A SAFE DIRECTION, OR INTO A PLASTIC BAG.**

16. Using a T-10 Torx wrench, remove the Pad Adjust Knob. Remove the detent ball bearing and spring located directly beneath the Pad Adjust Knob with a pick.

**IMPORTANT: BE CAREFUL NOT TO LOSE THE DETENT BALL BEARING AND SPRING WHEN REMOVING THE PAD ADJUST KNOB. YOU MAY WANT TO HOLD OVER A CLEAN RAG WHILE PERFORMING THIS STEP.**

17. Gently push the bevel gear out of the lever body from the backside using a pick or your thumb.

### PISTON/SPRING ASSEMBLY OVERHAUL

18. Remove the spring from the piston/spring assembly.
19. Using a small flathead screwdriver, remove the spring coupling from the piston, followed by the cupseal, glide ring and secondary quadseal o-ring.
20. Install a new quadseal o-ring, followed by the glide ring and a new cupseal with the open end out (not pictured).
21. Install the spring coupling back onto the piston and snap the return spring back onto the spring coupling.

### INTERNALS INSTALLATION

22. Install the bevel gear into the gear bore and hold in place with your finger.
23. Install the detent spring and ball into the lever body.
24. Align the Pad Adjust Knob with the bevel gear and install the knob using a T-10 Torx wrench. Tighten the knob to 1-1.2 N·m (8.7-10.4 in-lb). The bevel gear should now be secure and you no longer need to hold it in place with your finger.

15



16

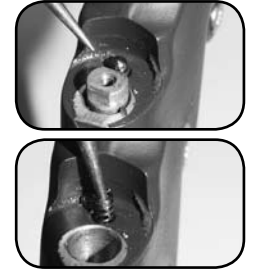

17

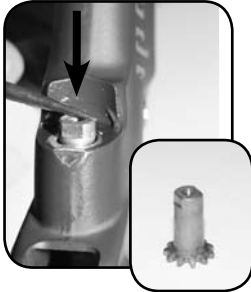

18



19



21

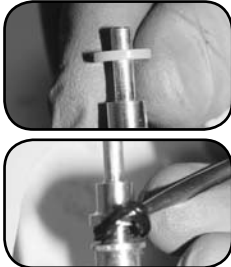

22



23

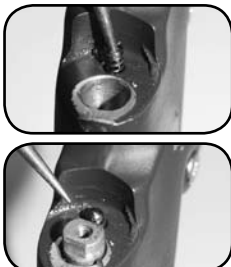

24



## LEVER OVERHAUL SERVICE INSTRUCTIONS (CONT)

### INTERNALS INSTALLATION (CONT)

25. Install the piston/spring assembly into the lever body.  
**IMPORTANT: ALIGN THE BLACK PISTON KEY ON THE PISTON GEAR INTO THE KEYWAY ON THE LEVER BODY.**
26. Push the piston/spring assembly far enough into the lever body to completely depress the spring. While the spring is depressed, insert a pin gauge (a small drill bit or 1.5 mm hex will work) into the compensating port, to hold the assembly compressed in the lever body.  
**IMPORTANT: DO NOT LOOK DIRECTLY INTO LEVER BODY WHILE PERFORMING THIS STEP. DEPRESSING THE SPRING PUTS IT INTO A PRELOADED CONDITION AND IT CAN EJECT RAPIDLY FROM THE LEVER BODY IF THE PIN GAUGE IS NOT PROPERLY INSTALLED.**
27. Install the pushrod then washer onto the top of the piston gear. Install the retaining ring in the groove of the lever body using a pair of snap ring pliers and orient the ring holes away from the lever body opening.
28. Remove the gauge pin from the compensating port. The piston assembly will snap into place against the pushrod and washer.

25



26



27



28



29



30



- LEVER BLADE/CAM INSTALLATION**
29. Insert a leg of the lever return spring into the hole on the lever cam.
30. Install the lever blade onto the cam and return spring, making sure the exposed spring leg is seated into the hole on the lever blade. With your thumb, roll the cam on the brake lever so that the lever pivot holes are aligned.
- NOTE: YOU CAN USE A 5 MM CABLE FERRULE AS A TOOL TO HOLD THE CAM AND LEVER BLADE TOGETHER AS YOU INSTALL THE ASSEMBLY TO THE LEVER BODY.**
31. Press pushrod coupling back into slot in cam.
32. Insert the lever blade assembly into the lever body at a slight angle. The pushrod coupling should snap firmly onto the exposed pushrod.
33. Rotate the lever so that the pivot and lever body bores are aligned and push the lever pivot sleeve bolt through the bearing. Using a 4 mm hex wrench, tighten sleeve bolt to 2-2.5 N-m (17-22 in-lb).

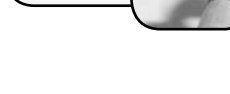

31



32



FERRULE TOOL

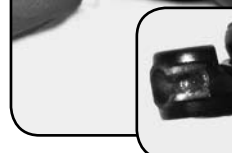

33



FERRULE TOOL

**NOTE: IF YOU USED A FERRULE TOOL IN STEP 30, INSTALLING THE PIVOT SLEEVE BOLT WILL PUSH OUT THE FERRULE TOOL. BE SURE THE BOLT TOOL IS COMPLETELY REMOVED.**

## LEVER OVERHAUL SERVICE INSTRUCTIONS (CONT)

### LEVER BLADE/CAM INSTALLATION (CONT)

33. Squeeze the lever a few times to ensure that the lever depressed and returns fully (not pictured).
34. Rotate the Pad Adjust Knob to the "full in" and the "full out" position to ensure full range of adjustment (not pictured).
35. Install the bladder reservoir cap using a T-10 Torx wrench and tighten to 1-1.2 N·m (8.7-10.4 in-lb).

35



**THIS CONCLUDES THE LEVER OVERHAUL SERVICE INSTRUCTIONS. YOU HAVE DONE A GREAT JOB AND ARE READY TO MOVE ON TO CODE HYDRAULIC DISC BRAKE CALIPER OVERHAUL, PAGE 29. ENJOY!**





# **DISC BRAKE CALIPER OVERHAUL**

# ELIXIR R, CR

## INTRODUCTION

Avid caliper assemblies need to be serviced in order to optimize braking function. If caliper brake piston motion is 'sticky' or lacks a positive and smooth return, the caliper body/brake piston o-ring may be out of place or damaged. If your brake was filled with brake fluid other than DOT 4 or 5.1, damage to all rubber and plastic internal parts may exist. Commonly used INCORRECT fluid is mineral oil or DOT 5, which is silicone based. Inspection and/or replacement of these parts, due to any of the above situations, will be necessary to restore proper brake function.

## CALIPER OVERHAUL SERVICE INSTRUCTIONS

### TROUBLESHOOTING -

#### 'STICKY' OR SLOW BRAKE PAD RETURN FEEL

Before completely disassembling your caliper, it's worth trying to loosen the sticky piston. Try the following: Clamp bicycle in bicycle work stand. Spin affected wheel. Lightly squeeze brake lever and watch brake pads when lever is released. Determine which side of the caliper has a slow returning brake piston. Remove caliper from bicycle. If you have a mounting bracket, it is recommended to remove that too or just remove the caliper leaving the bracket on the fork or frame. Remove e-clip from guide pin groove on top of the caliper. Using a 2.5 mm hex wrench remove the guide pin from the caliper. Pull and remove both brake pads and h-spring. Using a 10 mm box wrench, press working piston into caliper body. Squeeze brake lever slowly to move sticky piston inward. Press the piston back into the caliper again. Repeat these steps to correct caliper piston inner o-ring position. Both pistons should now be moving freely. Re-install spring pad clip, h-spring, and pads into caliper. Re-install caliper onto bicycle. Spin wheel, check function. If there is no improvement, continue with caliper service.



### GETTING STARTED

1. Remove brake caliper from fork or frame and remove the caliper mounting bracket and CPS hardware from the caliper. Set aside in correct order (not pictured).

#### BRAKE PAD AND H-SPRING REMOVAL

2. Remove e-clip from guide pin groove on top of the caliper. Using a 2.5 mm hex wrench remove the guide pin from the caliper.
3. Pull and remove both brake pads and h-spring.

**NOTE: IF THE TOTAL THICKNESS OF THE BACKING PLATE AND PAD FRICTION MATERIAL IS LESS THAN 3 MM, THE BRAKE PADS NEED TO BE REPLACED.**

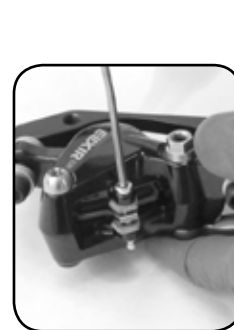
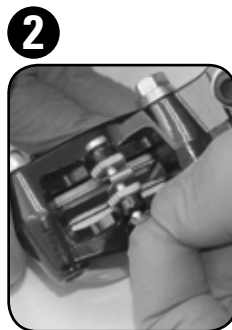

## CALIPER OVERHAUL SERVICE INSTRUCTIONS (CONT)

### ELIIXIR CR ONLY: BRAKE HOSE/BANJO BOLT REMOVAL AND SERVICE

4. Using an 8 mm open-end or box wrench, loosen banjo bolt. Brake fluid will leak, so hold over a container to catch fluid.
5. Pull banjo bolt completely out of caliper. Dump all caliper brake fluid into container.
6. Remove and replace o-ring on banjo bolt and banjo.

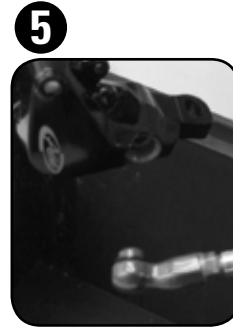
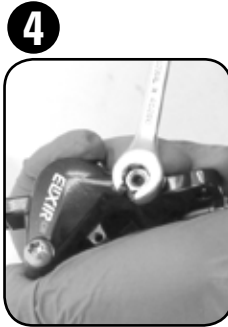

### CALIPER DISASSEMBLY AND SERVICE

7. Using an 8 mm and T 30 Torx loosen and remove the caliper body bolts.
8. Separate caliper body halves and open caliper assembly.
9. Using a sharp pick, remove small banjo hole (body half) o-ring.

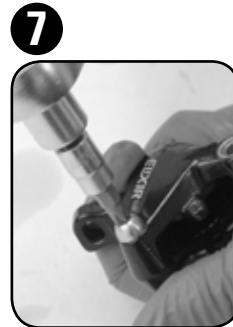

### BRAKE PISTONS REMOVAL AND SERVICE

10. Inboard Caliper Body Half: Using an air compressor chuck, insert chuck nozzle into banjo bolt hole. Hold caliper in one hand, pointing caliper piston in a safe direction. Hold one finger over the banjo bolt through-hole on opposite side of caliper body so air does not escape. Squeeze the air chuck and force air into the banjo bolt hole while holding caliper body. Compressed air unseats the caliper piston from the caliper. Pull out completely and remove piston.

**IMPORTANT: POINT THE CALIPER IN A SAFE DIRECTION. USE A CLOTH OR A PLASTIC BAG TO PREVENT THE PISTON CAUSING INJURY OR BECOMING LOST.**

Outboard Caliper Body Half: Using an air compressor chuck, insert chuck nozzle into banjo bolt hole. Hold caliper in one hand, pointing caliper piston in a safe direction. Hold one finger over the banjo bolt through-hole on opposite side of caliper body so air does not escape. Squeeze the air chuck and force air into the banjo bolt hole while holding caliper body. Compressed air unseats the caliper piston from the caliper. Pull out completely and remove piston.

**IMPORTANT: POINT THE CALIPER IN A SAFE DIRECTION. USE A CLOTH OR A PLASTIC BAG TO PREVENT THE PISTON CAUSING INJURY OR BECOMING LOST.**

11. Remove the square-edge o-ring from inside each caliper body half with a sharp pick and replace with new square-edge o-rings.

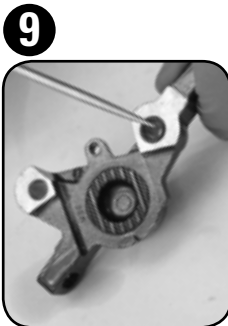

## CALIPER OVERHAUL SERVICE INSTRUCTIONS (CONT)

### CALIPER ASSEMBLY

12. Inspect caliper pistons for damage and replace if necessary. Re-install caliper brake pistons into each half of the caliper body. Make sure the piston slots are vertical in caliper body. (this keeps the fluid slots on the back side of piston lined up with fluid ports).
13. Using a sharp pick, remove and replace the outboard caliper body o-ring.
14. Using a T-30 Torx and an 8 mm open ended wrench, re-install the caliper body bolts and torque to 8.5-10.2 N·m (75-90 in-lb).
15. Using a T-10 Torx wrench, remove bleed screw.
16. Using a sharp pick, remove bleed screw o-ring. This o-ring may be a little hard to see. Replace with a new bleed screw o-ring.
17. Re-install banjo bolt bleed screw into banjo bolt and tighten with T-10 Torx wrench.

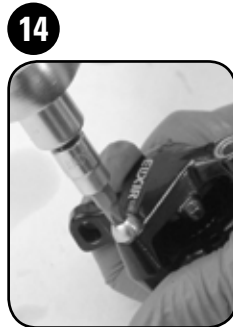
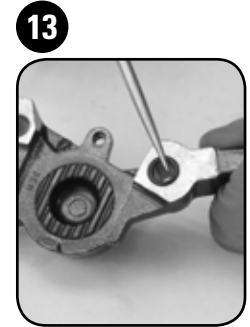
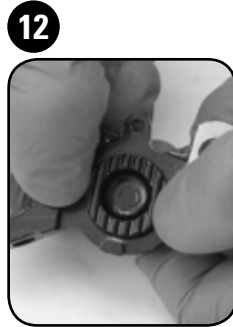

- ### BRAKE PAD INSTALLATION
18. Measure the total thickness of each pad (pad backing plate and pad material). If there is less than 3 mm of total width, replace both brake pads (not pictured).
  19. Be sure the h-spring is oriented to the pads as shown. Align the hole in the h-spring with the holes in the pad tabs. Squeeze the pad and spring assembly together, then insert into the caliper as a unit. Firmly push until the assembly is seated into place.
  20. Using a 2.5 mm hex wrench, install the pad retainer bolt and tighten to 0.9-1.1 N·m (8-9.5 in-lb). Install the "E" clip on the wheel side of the caliper making sure it sits in the groove of the retainer bolt

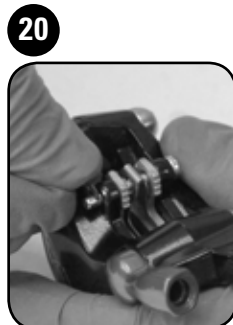

- ### FINISHING UP (NOT PICTURED)
21. Visually check your work. Inspect banjo bolt and banjo for any protruding o-rings. If there are any o-rings that are 'squeezed' beyond the outside edges of the banjo or bolt, remove and replace. Repeat installation steps.
  22. Wipe assembled caliper with soapy water to remove any brake fluid.
  23. Re-install caliper onto bicycle following the installation and torque specifications called out in the user manual.

**THIS CONCLUDES THE CALIPER OVERHAUL SERVICE INSTRUCTIONS. YOU HAVE DONE A GREAT JOB AND ARE READY TO MOVE ON TO THE NEXT CHAPTER, HYDRAULIC DISC BRAKE HOSE LENGTH ADJUSTMENT AND BLEEDING. ENJOY!**

# JUICY 3, 5, 7, CARBON

## INTRODUCTION

Avid caliper assemblies need to be serviced in order to optimize braking function. If caliper brake piston motion is 'sticky' or lacks a positive and smooth return, the caliper body/brake piston o-ring may be out of place or damaged. If your brake was filled with brake fluid other than DOT 4 or 5.1, damage to all rubber and plastic internal parts may exist. Commonly used INCORRECT fluid is mineral oil or DOT 5, which is silicone based. Inspection and/or replacement of these parts, due to any of the above situations, will be necessary to restore proper brake function.

## CALIPER OVERHAUL SERVICE INSTRUCTIONS

### TROUBLESHOOTING -

#### 'STICKY' OR SLOW BRAKE PAD RETURN FEEL

Before completely disassembling your caliper, it's worth trying to loosen the sticky piston. Try the following: Clamp bicycle in bicycle work stand. Spin affected wheel. Lightly squeeze brake lever and watch brake pads when lever is released. Determine which side of the caliper has a slow returning brake piston. Remove caliper from bicycle. If you have a mounting bracket, it is recommended to remove that too or just remove the caliper leaving the bracket on the fork or frame. Using a pair of needle-nosed pliers, remove both brake pads and h-spring. Remove the spring pad clip from the outside of the caliper. Using an 11mm box wrench, press working piston into caliper body. Squeeze brake lever slowly to move sticky piston inward. Press the piston back into the caliper again. Repeat these steps to correct caliper piston inner o-ring position. Both pistons should now be moving freely. Re-install spring pad clip, h-spring, and pads into caliper. Re-install caliper onto bicycle. Spin wheel and check function. If there is no improvement, continue with caliper service.



### GETTING STARTED

1. Remove brake caliper from fork or frame and remove the caliper mounting bracket and CPS hardware from the caliper. Set aside in correct order (not pictured).

#### BRAKE PAD AND H-SPRING REMOVAL

2. Using needle-nosed pliers, grab one of the pad tabs and slide the pad toward the center of the caliper (this disengages the pad backing plate from the post in the center of the piston), then pull the pad straight out. Repeat for other pad.

**NOTE: IF THE H-SPRING DOESN'T COME OUT WITH THE SECOND PAD, PUSH IT OUT FROM THE OPEN TOP OF THE CALIPER WITH A PICK OR YOUR FINGER.**

3. Remove the spring pad clip from the outside of the caliper.



## CALIPER OVERHAUL SERVICE INSTRUCTIONS (CONT)

**NOTE: IF THE TOTAL THICKNESS OF THE BACKING PLATE AND PAD FRICTION MATERIAL IS LESS THAN 3 MM, THE BRAKE PADS NEED TO BE REPLACED.**

### BRAKE HOSE/BANJO BOLT REMOVAL AND SERVICE

4. Using an 8 mm open-end or box wrench, loosen banjo bolt. Brake fluid will leak, so hold over a container to catch fluid.
5. Pull banjo bolt completely out of caliper. Dump all caliper brake fluid into container.
6. Remove o-rings on each side of brake hose banjo and replace with new o-rings.
7. Insert banjo bolt back into brake hose banjo. Ensure outside banjo o-ring is not damaged by banjo bolt threads. This may cause a leak. Set hose and banjo bolt aside.

### CALIPER DISASSEMBLY AND SERVICE

8. Loosen all three caliper body bolts with a 4 mm hex wrench. There are three different bolt lengths. Set aside in correct order.
9. Separate caliper body halves and open caliper assembly.
10. Using a sharp pick, remove small banjo hole (body half) o-ring.

### BRAKE PISTONS REMOVAL AND SERVICE

11. Inboard Caliper Body Half: Using an air compressor chuck, insert chuck nozzle into banjo bolt hole. Hold caliper in one hand, pointing caliper piston in a safe direction. Squeeze the air chuck and force air into the banjo bolt hole while holding caliper body. Compressed air unseats the caliper piston from the caliper. Pull out completely and remove piston.

**IMPORTANT: POINT THE CALIPER IN A SAFE DIRECTION. USE A CLOTH OR A PLASTIC BAG TO PREVENT THE PISTON CAUSING INJURY OR BECOMING LOST.**

12. Outboard Caliper Body Half: Using an air compressor chuck, insert chuck nozzle into banjo bolt hole. Hold caliper in one hand, pointing caliper piston in a safe direction. Hold one finger over the banjo bolt through-hole on opposite side of caliper body so air does not escape. Squeeze the air chuck and force air into the banjo bolt hole while holding caliper body. Compressed air unseats the caliper piston from the caliper. Pull out completely and remove piston.

**IMPORTANT: POINT THE CALIPER IN A SAFE DIRECTION. USE A CLOTH OR A PLASTIC BAG TO PREVENT THE PISTON CAUSING INJURY OR BECOMING LOST.**

13. Remove the square-edge o-ring from inside each caliper body half with a sharp pick and replace with new square-edge o-rings.



## CALIPER OVERHAUL SERVICE INSTRUCTIONS (CONT)

### CALIPER ASSEMBLY

14. Inspect caliper pistons for damage and replace if necessary. Re-install caliper brake pistons into each half of the caliper body.
15. Install a new banjo bolt o-ring into the banjo bolt hole on outboard side of caliper body.
16. Insert and thread caliper bolt into caliper closest to banjo bolt hole. Ensure new caliper banjo bolt o-ring is not unseated from its position (not pictured).
17. Insert remaining two caliper body bolts and tighten all three bolts with a 4 mm hex wrench to 4.9-5.9 N-m (43 - 52 in-lb).
18. Insert banjo bolt back into caliper into banjo bolt hole. Hand-thread and tighten with 8 mm box wrench to 4.9-5.9 N-m (43 - 52 in-lb). Be careful not to pinch either of these o-rings during installation.
19. Using a T-10 Torx wrench, remove banjo bolt bleed screw.
20. Using a sharp pick, remove bleed screw o-ring. This o-ring may be a little hard to see. Replace with a new bleed screw o-ring.
21. Re-install banjo bolt bleed screw into banjo bolt and tighten with T-10 Torx wrench.

14



15



17



18



19



20



21



22



24



### BRAKE PAD INSTALLATION

22. Insert spring pad clip into outer side of caliper.
23. Measure the total thickness of each pad (pad backing plate and pad material). If there is less than 3 mm of total width, replace both brake pads (not pictured).
24. Position the h-spring between the two pads. The curved handle of inner pad should face toward inboard side of caliper. Squeeze the pad and spring assembly together, then firmly push into the caliper until it 'clicks' into place, indicating it is properly secured in the caliper body.

### FINISHING UP (NOT PICTURED)

24. Visually check your work. Inspect banjo bolt and banjo for any protruding o-rings. If there are any o-rings that are 'squeezed' beyond the outside edges of the banjo or bolt, remove and replace. Repeat installation steps.
25. Wipe assembled caliper with soapy water to remove any brake fluid.
26. Re-install caliper onto bicycle following the installation and torque specifications called out in the user manual.



**THIS CONCLUDES THE CALIPER OVERHAUL SERVICE INSTRUCTIONS. YOU HAVE DONE A GREAT JOB AND ARE READY TO MOVE ON TO THE NEXT CHAPTER, HYDRAULIC DISC BRAKE HOSE LENGTH ADJUSTMENT AND BLEEDING. ENJOY!**

# JUICY ULTIMATE

## INTRODUCTION

Avid caliper assemblies need to be serviced in order to optimize braking function. If caliper brake piston motion is 'sticky' or lacks a positive and smooth return, the caliper body/brake piston o-ring may be out of place or damaged. If your brake was filled with brake fluid other than DOT 4 or 5.1, damage to all rubber and plastic internal parts may exist. Commonly used INCORRECT fluid is mineral oil or DOT 5, which is silicone based. Inspection and/or replacement of these parts, due to any of the above situations, will be necessary to restore proper brake function.

## CALIPER OVERHAUL SERVICE INSTRUCTIONS

### TROUBLESHOOTING -

#### 'STICKY' OR SLOW BRAKE PAD RETURN FEEL

Before completely disassembling your caliper, it's worth trying to loosen the sticky piston. Try the following: Clamp bicycle in bicycle work stand. Spin affected wheel. Lightly squeeze brake lever and watch brake pads when lever is released. Determine which side of the caliper has a slow returning brake piston. Remove caliper from bicycle. If you have a mounting bracket, it is recommended to remove that too or just remove the caliper leaving the bracket on the fork or frame. Using a pair of needle-nosed pliers, remove both brake pads and h-spring. Using an 11 mm box wrench, press working piston into caliper body. Squeeze brake lever slowly to move sticky piston inward. Press the piston back into the caliper again. Repeat these steps to correct caliper piston inner o-ring position. Both pistons should now be moving freely. Re-install h-spring and pads into caliper. Re-install caliper onto bicycle. Spin wheel and check function. If there is no improvement, continue with caliper service.

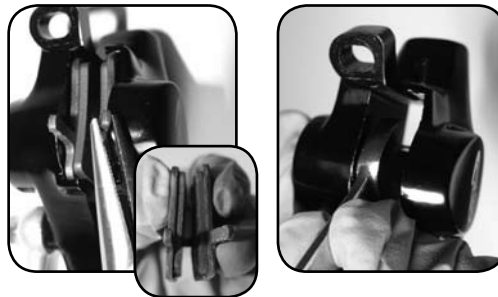

### GETTING STARTED

1. Remove brake caliper from fork or frame and remove the caliper mounting bracket and CPS hardware from the caliper. Set aside in correct order (not pictured).

#### BRAKE PAD AND H-SPRING REMOVAL

2. Using needle-nosed pliers, grab one of the pad tabs and slide the pad toward the center of the caliper (this disengages the pad backing plate from the post in the center of the piston), then pull the pad straight out. Repeat for other pad.



**NOTE: IF THE H-SPRING DOESN'T COME OUT WITH THE SECOND PAD, PUSH IT OUT FROM THE OPEN TOP OF THE CALIPER WITH A PICK OR YOUR FINGER.**

**NOTE: IF THE TOTAL THICKNESS OF THE BACKING PLATE AND PAD FRICTION MATERIAL IS LESS THAN 3 MM, THE BRAKE PADS NEED TO BE REPLACED.**



## CALIPER OVERHAUL SERVICE INSTRUCTIONS (CONT)

### BRAKE HOSE/BANJO BOLT REMOVAL AND SERVICE

3. Using an 8 mm open-end or box wrench, loosen banjo bolt. Brake fluid will leak, so hold over a container to catch fluid.
4. Pull banjo bolt completely out of caliper. Pour all caliper brake fluid into container.
5. Remove o-ring from brake hose banjo and banjo bolt and replace with new o-rings.
6. Insert banjo bolt back into brake hose banjo. Ensure outside banjo o-ring is not damaged by banjo bolt threads. This may cause a leak. Set hose and banjo bolt aside.



### BRAKE PISTON REMOVAL AND SERVICE

7. Using an 11 mm box wrench, gently push outboard piston into caliper body until it is flush with the inside of the caliper.
8. Gently press a flathead screwdriver against the outboard piston while pointing the caliper in a safe direction (you want to remove the inboard piston first, so you need to hold the outboard piston in place). Using an air compressor chuck, insert chuck nozzle into banjo bolt through hole. Squeeze the air chuck and force air into the banjo bolt hole. Compressed air unseats the inboard caliper piston from the caliper. Pull the piston out of the caliper body through pad opening.

**NOTE: YOU MAY NEED TO USE A PAIR OF NEEDLE NOSED PLIERS TO PULL THE PISTON OUT OF THE CALIPER BODY. BE CAREFUL NOT TO SCRATCH THE PISTON. IF YOU SCRATCH THE PISTON, YOU WILL NEED TO REPLACE IT.**

**IMPORTANT: BE SURE TO POINT THE CALIPER IN A SAFE DIRECTION. YOU MAY WANT TO DO THIS INSIDE A PLASTIC BAG TO PREVENT THE PISTON FROM CAUSING INJURY OR BECOMING LOST.**

9. Using an 8 mm hex wrench, turn the piston cap clockwise to push the outboard piston into and out of the caliper body. Pull the piston out of the caliper body through the pad opening.
10. Press the piston cap into the caliper body and remove through the pad opening.
11. Using a sharp pick, remove the piston cap o-ring and replace with a new o-ring.
12. Using a sharp pick, remove the inboard and outboard quad seal o-rings from the caliper body and replace with new o-rings.

**NOTE: WHEN INSTALLING THE NEW QUAD SEAL O-RINGS, USE THE FLAT SIDE OF A PICK TO SEAT THE O-RING INTO THE O-RING GROOVE BY MOVING IT AROUND THE ENTIRE SEAL.**

13. Using a T-10 Torx, remove caliper body assembly bleed screw.
14. Using a sharp pick, remove bleed screw o-ring and replace with a new one.

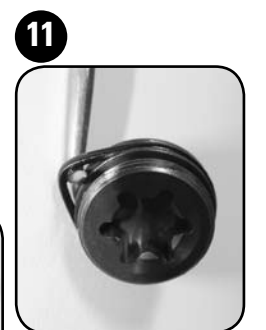

## CALIPER OVERHAUL SERVICE INSTRUCTIONS (CONT)

### BRAKE PISTON INSTALLATION

15. Inspect caliper pistons for damage and replace if necessary (not pictured).
16. Install inboard piston through the pad opening, pressing it flush into the caliper body with an 11 mm box wrench.
17. Install piston cap through pad opening. Using an 8 mm hex wrench, thread piston cap counter-clockwise until snug into caliper body.
18. Install the outboard piston through the pad opening and press it flush into the caliper body with an 11 mm box wrench.
19. Using a T-10 Torx, install caliper body assembly bleed screw.

16



17



18



19



20



21



- ### BRAKE HOSE/BANJO BOLT INSTALLATION
20. Insert banjo bolt back into caliper banjo bolt hole setting the banjo angle to the desired angle. Hand-thread and tighten with 8 mm box wrench to 4.9-5.9 N·m (43 - 52 in-lb). Be careful not to pinch the banjo bolt o-ring during installation.
  21. Using a T-10 Torx wrench, remove banjo bolt bleed screw.
  22. Using a sharp pick, remove bleed screw o-ring. This o-ring may be a little hard to see. Replace with a new bleed screw o-ring.
  23. Re-install banjo bolt bleed screw into banjo bolt and tighten with T-10 Torx wrench.

22



23



25



### BRAKE PAD INSTALLATION

24. Measure the total thickness of each pad (pad backing plate and pad material). If there is less than 3 mm of total width, replace both brake pads (not pictured).
25. Position the h-spring between the two pads. The curved handle of inner pad should face toward inboard side of caliper. Squeeze the pad and spring assembly together, then firmly push into the caliper until it 'clicks' into place, indicating it is properly secured in the caliper body.



## CALIPER OVERHAUL SERVICE INSTRUCTIONS (CONT)

### FINISHING UP (NOT PICTURED)

24. Visually check your work. Inspect banjo bolt and banjo for any protruding o-rings. If there are any o-rings that are 'squeezed' beyond the outside edges of the banjo or bolt, remove and replace. Repeat installation steps.
25. Wipe assembled caliper with soapy water to remove any brake fluid.
26. Re-install caliper onto bicycle following the installation and torque specifications called out in the user manual.

**THIS CONCLUDES THE CALIPER OVERHAUL SERVICE INSTRUCTIONS. YOU HAVE DONE A GREAT JOB AND ARE READY TO MOVE ON TO THE NEXT CHAPTER, HYDRAULIC DISC BRAKE HOSE LENGTH ADJUSTMENT AND BLEEDING. ENJOY!**

# CODE, CODE 5

## INTRODUCTION

Avid caliper assemblies need to be serviced in order to optimize braking function. If caliper brake piston motion is 'sticky' or lacks a positive and smooth return, the caliper body/brake piston o-ring may be out of place or damaged. If your brake was filled with brake fluid other than DOT 4 or 5.1, damage to all rubber and plastic internal parts may exist. Commonly used INCORRECT fluid is mineral oil or DOT 5, which is silicone based. Inspection and/or replacement of these parts, due to any of the above situations, will be necessary to restore proper brake function.

## CALIPER OVERHAUL SERVICE INSTRUCTIONS

### TROUBLESHOOTING -

#### 'STICKY' OR SLOW BRAKE PAD RETURN FEEL

Before completely disassembling your caliper, it's worth trying to loosen the sticky piston. To do so, try the following: Clamp bicycle in bicycle work stand. Spin affected wheel. Lightly squeeze brake lever and watch brake pads when lever is released. Determine which side of the caliper has a slow returning brake piston. Remove caliper from bicycle. If you have a mounting bracket, it is recommended to remove that too or just remove the caliper leaving the bracket on the fork or frame. Remove e-clip from guide pin groove on top of the caliper using a sharp pick. Using a 2.5 mm hex wrench remove the guide pin from the caliper. Pull and remove both brake pads and h-spring. Using a 10 mm box wrench, press working piston into caliper body. Squeeze brake lever slowly to move sticky piston inward. Press the piston back into the caliper again. Repeat these steps to correct caliper piston inner o-ring position. Both pistons should now be moving freely. Re-install spring pad clip, h-spring, and pads into caliper. Re-install caliper onto bicycle. Spin wheel, check function. If there is no improvement, continue with caliper service.



### GETTING STARTED

1. Remove brake caliper from fork or frame and remove caliper mounting bracket and CPS hardware from caliper. Set aside in correct order (not pictured).

## CALIPER OVERHAUL SERVICE INSTRUCTIONS (CONT)

### BRAKE PADS AND PAD H-SPRING REMOVAL

2. Remove e-clip from guide pin groove on top of the caliper using a sharp pick.
3. Using a 2.5 mm hex wrench remove the guide pin from the caliper.
4. Squeeze the pads together so they clear the pistons, and pull to remove brake pads and h-spring from caliper.

**2**



**3**



**4**



### CALIPER DISASSEMBLY AND SERVICE

5. Using a 4 mm hex wrench, loosen all four caliper body bolts until there is slight gap in the caliper halves. This will ease banjo bolt removal.
6. Using two 4 mm hex wrenches, loosen and remove the banjo sleeve bolt and banjo shoulder bolt.
7. Completely remove all four caliper body bolts, separate the caliper body into its two halves and remove the banjo.
8. Using a sharp pick, remove the o-rings from underneath the heads of both the banjo sleeve bolt and banjo shoulder bolt and replace with new o-rings.
9. Using a sharp pick, remove the banjo o-rings on both the right and left side of the caliper halves and replace with new o-rings.

**5**



**6**



**7**



**8**



**8**



**9**



### BRAKE PISTON REMOVAL AND SERVICE

10. Using an air compressor chuck, insert chuck nozzle into banjo bolt hole. Hold caliper in a rag in one hand, using your thumb or finger to seal the backside of the banjo bolt hole. Squeeze the air chuck and force air into the banjo bolt hole. The compressed air will unseat the caliper piston from the piston pockets.

**10**



**11**



**IMPORTANT:** BE SURE TO POINT THE CALIPER IN A SAFE DIRECTION. YOU MAY WANT TO DO THIS INSIDE A PLASTIC BAG TO PREVENT THE PISTON FROM CAUSING INJURY OR BECOMING LOST.

**NOTE:** BECAUSE OF THE NATURE OF A FOUR PISTON CALIPER, BOTH PISTONS IN EACH HALF OF THE CALIPER MAY NOT BE UNSEATED SIMULTANEOUSLY. TO REMOVE THE SECOND PISTON USE YOUR THUMB TO SEAL THE EMPTY PISTON POCKET OR FIND A METRIC SOCKET EXTENSION THAT FITS SNUGLY INTO THE PISTON POCKET AND SEAL THE TOP OF THE EXTENSION WITH YOUR THUMB. REPEAT STEP 10 TO REMOVE THE LAST PISTON.

11. Remove the square edge o-ring from inside each piston pocket using a sharp pick and place with new o-rings.
12. Remove both banjo bolt bleed screws from the top of the caliper body using a T-10 Torx wrench.
13. Remove the o-rings from the bleed screws and replace with new o-rings.

**12**



**13**



## CALIPER OVERHAUL SERVICE INSTRUCTIONS (CONT)

### CALIPER ASSEMBLY

14. Inspect the caliper pistons for damage, and replace if necessary. Insert the caliper brake pistons back into each half of the caliper body.  
**NOTE: GENTLY ROLLING THE PISTONS CLOCKWISE AS YOU INSTALL WILL HELP WITH INSTALLATION.**
15. Place banjo sleeve bolt into the left half (out-board side) of the caliper. Slide banjo onto the sleeve bolt and set the banjo angle to the desired angle.
16. Align both caliper halves together and insert the banjo shoulder bolt and the four caliper body bolts. Using two 4 mm hex wrench, tighten the banjo bolt to 2.9-3.4 N·m (26-30 in-lb). Using a 4 mm hex wrench tighten the caliper body bolts to 5.9-6.3 N·m (52-56 in-lb).
17. Using a T-10 Torx, install the two bleed screws back into the top of the caliper body and tighten to .6-.7 N·m (5-6 in-lb).

### BRAKE PAD INSTALLATION

18. Inspect and measure each brake pad. If there is less than 3 mm of total pad thickness (pad backing and pad friction material), replace both brake pads (not pictured).
19. Position the h-spring between the two pads.  
**NOTE: THE CODE PADS ARE SYMMETRICAL, THERE IS NOT A LEFT OR RIGHT ORIENTATION.**
20. Locate the "pad installation" feature of the pad spacer tool. Insert the pad handles into the "pad installation" tool so it holds the pads together.
21. Insert the pads and pad tool into the caliper until the holes in the top of the pads are aligned with the guide pin holes in the top of the caliper.
22. Insert the guide pin through the caliper body halves and the brake pads. Using a 2.5 mm hex wrench, tighten the guide pin to 1.5-1.9 N·m (13-17 in-lb).
23. Remove the pad tool. The h-spring will snap the pads into position.
24. Using your thumb or finger, install the e-clip into the groove on the end of the guide pin.

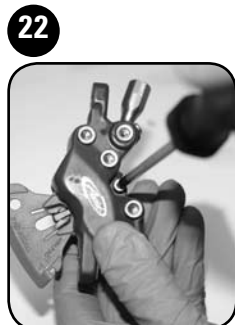

## CALIPER OVERHAUL SERVICE INSTRUCTIONS (CONT)

### FINISHING UP (NOT PICTURED)

27. Visually check your work. Inspect banjo bolt and banjo for any protruding o-rings. If there are any o-rings that are 'squeezed' beyond the outside edges of the banjo or bolt, remove and replace. Repeat installation steps.
28. Wipe assembled caliper with soapy water to remove any brake fluid.
29. Re-install caliper onto bicycle following the installation and torque specifications called out in the user manual.

**THIS CONCLUDES THE CALIPER OVERHAUL SERVICE INSTRUCTIONS. YOU HAVE DONE A GREAT JOB AND ARE READY TO MOVE ON TO THE NEXT CHAPTER, HYDRAULIC DISC BRAKE HOSE LENGTH ADJUSTMENT AND BLEEDING. ENJOY!**

# BB7 MOUNTAIN & ROAD

## INTRODUCTION

Avid caliper assemblies need to be serviced in order to optimize braking function. If caliper brake piston motion is 'sticky' or lacks a positive and smooth return, the caliper body/brake piston o-ring may be out of place or damaged. Inspection and/or replacement of these parts, due to any of the above situations, will be necessary to restore proper brake function.

## CALIPER OVERHAUL DISASSEMBLY SERVICE INSTRUCTIONS

### TROUBLESHOOTING (NOT PICTURED)

The most common issue with the BB7 is that the outboard pressure foot can become dislodged if the outboard adjustment knob is turned too far clockwise without the rotor in the caliper (wheel off or caliper removed). The brake is not broken, nor does it require disassembly to replace the pressure foot. To replace the pressure foot, turn the outboard adjuster knob counter-clockwise until it stops. If the knob doesn't stop, then the foot screw (the end of which can be seen in the center of the knob) has become disengaged from the knob and possibly from the threads inside the drive cam. In this case, remove the knob, then using a pair of small needle-nosed pliers or a schrader valve tool, turn the the foot screw all the way back out until it stops. Now the pressure foot can be replaced. Relocate the pressure foot into the bore, then give it a firm push in the center. It will click back into place. If you removed the knob, replace it and you're done!

### GETTING STARTED

1. Remove the cable anchor bolt and plate, then pull the cable housing and inner wire free of the caliper. Remove the rubber cable boots.

### REMOVE THE BRAKE PADS

2. Turn both adjuster knobs all the way out (counterclockwise), then squeeze the pad tabs together and pull both pads and pad spring clip straight out of the caliper.





## CALIPER OVERHAUL DISASSEMBLY SERVICE INSTRUCTIONS (CONT)

### REMOVE THE OUTBOARD KNOB

3. Remove the outboard pad knob with a small flat-head screwdriver. Be careful not to mar the surface of the torque arm.
4. Turn the foot screw which is now exposed counter-clockwise until it stops.

3



4



5



### REMOVE TORQUE ARM

5. Hold the spring loaded torque arm securely in place.
6. Remove the torque arm fixing nut using an 11 mm wrench. Remove the lockwasher.
7. Remove the torque arm, outer body seal, and spring. Then remove the hex-hole washer.

6



7



8



### REMOVE DRIVE CAM/OUTBOARD PRESSURE FOOT ASSEMBLY

8. Using a 5 mm hex, remove the 2 caliper body bolts.
- NOTE: THE BOLTS ARE DIFFERENT LENGTHS.**
9. Carefully remove the inboard caliper body half and set aside.
10. Remove the pad retaining clip and set aside.
11. Pull out the drive cam/outboard pressure foot assembly. Be careful not to lose any of the three ball bearings.
12. Use a 5mm hex to remove the outboard caliper body half from the bike and set aside.

### DRIVE CAM DISASSEMBLY

13. Use small needle-nosed pliers or a schrader valve core tool to turn the foot screw clockwise until it is completely unthreaded from the drive cam. This will separate the outer pressure foot from the cam assembly. Remove the foot screw from the drive cam.

### REMOVE PRESSURE FOOT

14. Using a T-25 Torx wrench, turn the inboard pressure foot clockwise until it is free from the inboard caliper body half.

9



10



11



12



13



14



## CALIPER OVERHAUL CLEANING & INSPECTION INSTRUCTIONS

### CLEANING

- Clean all metal parts in alcohol, including the cable anchor bolt and plate. Clean the cable seal boots and outer caliper body seal in mild soap and water. Rinse and dry all parts completely (not pictured).

### CALIPER BODY INSPECTION

- Inspect both caliper body halves for any damage; pay close attention to all threaded surfaces.

### SMALL PART INSPECTION

- Check ball bearing and cam ramps for excessive wear.

**NOTE: IT IS NORMAL TO SEE BALL TRACKS IN THE CAM RAMPS.**

- Check the threads of the drive cam, foot screw, inner pressure foot, cable anchor bolt, and torque arm fixing nut for damage.
- Check the spring for any signs of damage.
- Check the cable seal boots for nicks, tears, or cracking.

16



17

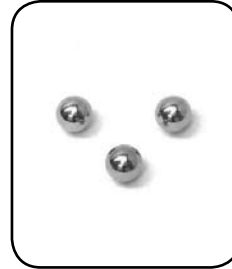

18



19

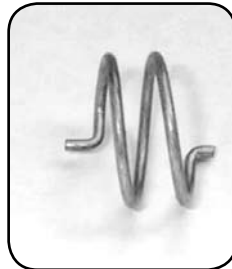

20



## CALIPER OVERHAUL ASSEMBLY SERVICE INSTRUCTIONS

### ASSEMBLE CALIPER

- Very lightly grease the inner pressure foot threads.
- Using a T-25 Torx wrench, thread the inner pressure foot into the outboard caliper body half until the pressure foot is flush with the inner face of the caliper body.
- Very lightly grease the foot screw threads, tip of stem-end on outer pressure foot, and the ramps of the drive cam.
- Using small needle-nosed pliers or a Schrader valve tool, thread the foot screw into the drive cam completely, but do not tighten.

21



22



23

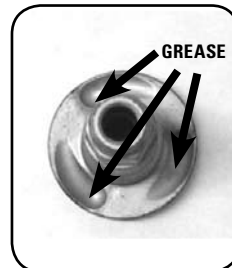
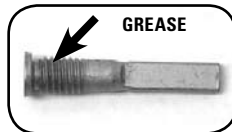

24



## CALIPER OVERHAUL ASSEMBLY SERVICE INSTRUCTIONS

### ASSEMBLE CALIPER (CONT)

25. Insert the stem-end of the outer pressure foot into the hole in the end of the drive cam and install by firmly pressing it straight in.

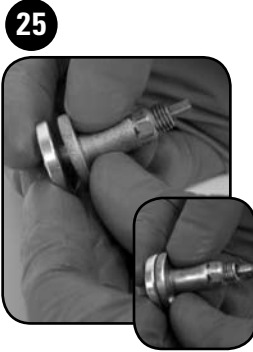

26. Lightly grease the ramps of the fixed cam in the outboard caliper body.

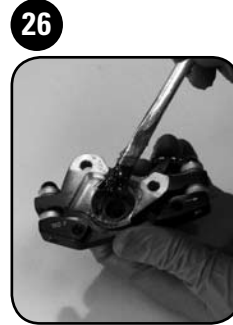

27. Place the ball bearings into the ramps of the fixed cam.



28. Insert the Drive Cam/Outer Pressure Foot assembly through the hole in the outboard caliper body. Rotate the cams against each other to ensure the ball bearings are seated properly in both sets of ramps.



29. Apply a high-strength thread-lock such as Loctite 272 to the drive cam threads.



**IMPORTANT: BE CAREFUL NOT TO ALLOW ANY THREAD-LOCK TO ENTER THE AREA AROUND THE FOOT SCREW.**

30. Hold the Drive Cam in place and re-install the return spring, outer seal, and washer with hex-hole.

**NOTE: THE SPRING LEG THAT EXTENDS AWAY FROM THE SPRING SHOULD POINT AWAY FROM THE CALIPER BODY. THE NOTCH IN THE OUTER SEAL SHOULD FACE AWAY FROM THE CALIPER BODY AND BE LOCATED UNDERNEATH THE SPRING LEG.**



31. Install the torque arm, aligning the spring leg with the spring tension notch on the back of the torque arm. When engaged correctly, the spring adjuster screw will be driven against the spring leg on the back of the torque arm. Press the torque arm onto the flats of the drive cam shaft. Make sure the arm is fully seated and hold firmly with your thumb.

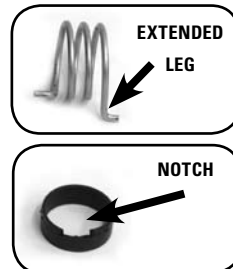

32. Place the lockwasher on the drive cam with the rounded side toward the caliper body. Thread on the torque arm fixing nut by hand, then torque to 55-60in-lb.



**IMPORTANT: DO NOT OVER TIGHTEN THE TORQUE ARM FIXING NUT.**

33. Install the outboard adjuster knob by aligning the rectangle tab of the foot screw with the rectangular hole in the the knob, then press it on firmly.



34. Re-install the pad retainer in the outboard caliper body.

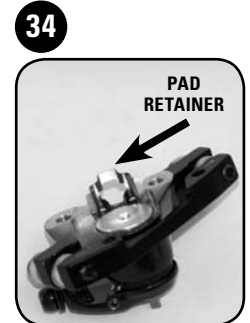

35. Apply a high-strength thread-lock such as Loctite 272 to the 2 caliper bolts.



36. Align both caliper halves together and insert the caliper body bolts. The short bolt goes in the hole near the cable anchor, and the long bolt goes in the hole near the housing stop. Torque both bolts to 75-90 in-lb.



**NOTE: BE CAREFUL TO KEEP THE PAD RETAINER IN PLACE WHILE JOINING THE HALVES TOGETHER.**



## CALIPER OVERHAUL ASSEMBLY SERVICE INSTRUCTIONS

### INSTALL THE NEW PADS AND SPRING

36. Assemble the spring between the new left and right pads. Align the spring to the pad as shown. Squeeze the brake pad and spring clip assembly together then press firmly into the caliper until it “clicks” into place. The pad marked “R” goes on the spoke side of the brake.
37. Push the upper and lower boots onto the integrated cable stop.
38. Place the cable anchor plate on the cable anchor bolt, grease the bolt lightly and install into the torque arm. (not pictured)
39. Re-mount the caliper onto the bike.
40. Set up the brake by following the procedures in the Avid Ball Bearing Disk Brake Installation Guidelines. Be sure to torque to the proper value.

36



37

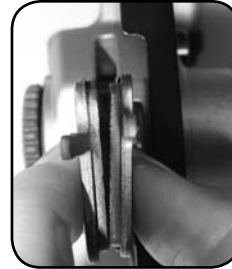

39



## COMPLETING BALL BEARING DISC BRAKE CALIPER OVERHAUL

You are almost ready to ride, but first it's a good idea to test your brakes by pulling on the lever extremely hard (as hard as you can imagine yourself pulling the lever while you're riding) several times. Check that the caliper closes and returns properly. Make one last check of all the bolts and fittings.

If everything checks out, **YOU ARE READY TO RIDE!**

# **HYDRAULIC DISC BRAKE HOSE LENGTH ADJUSTMENT & BLEED**

# ELIXIR R, CR - JUICY 3, 5, 7, CARBON, ULTIMATE - CODE, CODE 5

## INTRODUCTION

Avid brakes come with the hoses attached and bled. If you don't need to change the hose length, then you should not need to bleed the system again. However, if you performed a lever and/or caliper overhaul, you will need to bleed your brakes. Bleeding is one of the most important steps in topping off the performance of any hydraulic brake system. Any air inside a hydraulic brake system degrades the performance of the brake. The goal of bleeding is to remove the air that is trapped in the hoses, caliper or lever.

## CHANGING HOSE LENGTHS

### RE-CHECK HOSE ROUTING

1. Since you can't lengthen the hose after you have cut it, take a moment and re-check the routing of the hoses. Be sure to account for suspension movement and check that the bars turn freely by turning the bars all the way from side to side. Make sure the hoses are properly secured as well (not pictured).

### REMOVE HOSE FROM LEVER

2. **Juicy, Code & Elixir R:** Use an 8 mm open ended wrench to unscrew the hose compression nut  
**Elixir CR:** Use an 11 mm open ended wrench to hold the hose stop in place and use an 8 mm open ended wrench to unscrew the hose compression nut.

**NOTE: IF YOUR BRAKE HAS A HOSE BOOT, PULL THE BOOT AWAY FROM THE LEVER TO ACCESS THE COMPRESSION NUT. IF THE BOOT STICKS, CAREFULLY PRY UP A CORNER WITH SOMETHING THAT WON'T HARM IT (LIKE A PENCIL TIP) AND SPRAY SOME ALCOHOL BETWEEN THE BOOT AND THE LEVER. WORK THE ALCOHOL IN; THE BOOT SHOULD LOOSEN UP AND SLIDE EASILY DOWN THE HOSE.**

3. Pull the hose from the lever, wiggling it if necessary. Be careful, DOT fluid will drip from the hose. Try not to spill too much fluid because any fluid that drips out will create bubbles that you'll have to eliminate later.
4. Slide the nut and boot (if applicable) down the hose and away from the end where you'll be cutting. Do not to engage the brake lever while the hose is removed (not pictured).

2



3



## CHANGING HOSE LENGTHS (CONT)

### DETERMINE PROPER HOSE LENGTH & CUT

5. Determine where you need to cut the hose by holding it up to the lever in the position you like. Make sure to leave a gentle bend in the hose with enough length to freely turn the bars all the way from side to side. Double-check this part, because you can't go back after you cut.
6. The groove in the lever nose marks the spot where you'll cut the hose. Cut the hose using hydraulic hose cutters or very sharp cable-housing cutters (not pictured).



### INSTALL NEW FITTINGS

7. While holding the hose firmly, thread a new hose barb into the end of the hose using a T-10 Torx wrench.
8. Slide a new compression fitting over the end of the hose with the new hose barb.

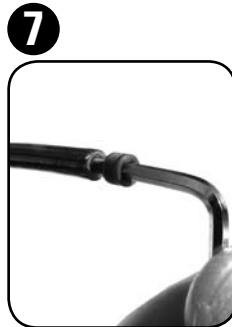

### RE-INSTALL THE HOSE

9. Push the hose firmly into the lever until it stops.
  10. While holding the hose in place, slide the compression fitting and compression nut up to the lever or hose stop (not pictured).
- Juicy, Code & Elixir R:** Finger-tighten the compression nut until you feel it bottom out.
- Elixir CR:** Hold the hose stop in place and finger-tighten the compression nut until you feel it bottom out.- 11. **Juicy, Code & Elixir R:** While continuing to push the hose into the lever body, use an 8 mm open ended wrench to tighten the compression nut to the proper torque.

**Elixir CR:** While continuing to push the hose into the hose stop, use an 11 mm open ended wrench to hold the hose stop in place and use an 8 mm open ended wrench to tighten the compression nut to the proper torque.



If your compression fitting is alloy, tighten to 5 N·m (47 in·lb). If your compression fitting is steel, tighten to 7.8 N·m (70 in·lb).

12. Slide the boot (if applicable) back into place (not pictured).

**IMPORTANT: CUTTING DOWN THE HOSE INTRODUCES A SMALL AMOUNT OF AIR INTO THE SYSTEM, WHICH CAN DEGRADE THE PERFORMANCE OF YOUR BRAKES. AT THIS POINT, IT IS NECESSARY TO BLEED THE BRAKES TO RESTORE THEM TO OPTIMAL PERFORMANCE. PLEASE CONTINUE ON TO "BLEEDING PROCEDURES".**

## BLEEDING PROCEDURE

WHEN BLEEDING AVID BRAKES, KEEP IN MIND THAT YOU ARE SIMPLY CHASING BUBBLES OUT OF THE SYSTEM. AVID RECOMMENDS THAT YOU BLEED YOUR BRAKES AT LEAST ONCE A YEAR TO ENSURE OPTIMAL PERFORMANCE. IF YOU RIDE FREQUENTLY OR IN AGGRESSIVE TERRAIN, YOU SHOULD BLEED YOUR BRAKES MORE OFTEN. YOU WILL PERFORM 3 BASIC OPERATIONS WHEN BLEEDING AVID BRAKES: BLEED THE HOSE, BLEED THE CALIPER, BLEED THE LEVER.

### PREPARE THE SYRINGES

1. Fill one syringe 1/2 full with Avid Hi-Performance DOT Fluid and fill the other syringe 1/4 full.
2. Hold each syringe with the tip pointed up and tap the side of the syringe with your finger to bring any air bubbles to the top. Place a towel around the tip and slowly push the air bubbles out of the syringe.

**NOTE: YOU WILL NOT BE ABLE TO REMOVE ALL THE BUBBLES.**

1



2



### PREPARE THE CALIPER

#### JUICY 3, 5, 7, ULTIMATE & CARBON ONLY

3. Remove the wheel from your bike. Remove the brake pads and spreader clip from the caliper and insert the appropriate Bleed Block. This will help prevent DOT fluid from contaminating your brake pads (not pictured).
4. Use the T-10 Torx wrench to remove the caliper bleed port screw from the center of the banjo bolt.
5. Make sure the fluid in the 1/2 full syringe is pushed all the way to the tip (no air gap!), then thread into the caliper bleed port.

4



5



### PREPARE THE CALIPER

#### CODE/CODE 5 ONLY

6. Remove the wheel from your bike. Remove the brake pads and spreader clip from the caliper and insert the appropriate Bleed Block. This will help prevent DOT fluid from contaminating your brake pads (not pictured).
7. The Code caliper features two bleed port screws on either side on the banjo fitting. It's recommended that you use the bleed port on the left side of the banjo fitting during normal bleeding. Use the T-10 Torx wrench to remove the caliper bleed screw from the caliper body.
8. Make sure the fluid in the 1/2 full syringe is pushed all the way to the tip (no air gap!), then thread into the caliper bleed port.

7



8





## BLEEDING PROCEDURE (CONT)

### PREPARE THE CALIPER

#### ELIXIR R/ELIXIR CR

9. Remove the wheel from your bike. Remove the brake pads and spreader clip from the caliper and insert the appropriate Bleed Block. This will help prevent DOT fluid from contaminating your brake pads (not pictured).
10. Use the T-10 Torx wrench to remove the caliper bleed port screw from the caliper body.
11. Make sure the fluid in the 1/2 full syringe is pushed all the way to the tip (no air gap!), then thread into the caliper bleed port.

10



11



### PREPARE THE LEVER

12. **Reach Adjust:** For models equipped with Reach Adjust, ensure that the reach is not adjusted so far out that it causes the lever blade to bottom out on the lever body. Doing so can make bleeding the brake impossible (not pictured).
- Pad Contact Adjust:** For models equipped with Pad Contact Adjust, set the adjustment so it is turned all the way out (not pictured).
13. Use the T-10 Torx wrench to remove the lever bleed port screw.

13



14



15



14. Make sure the fluid in the 1/4 full syringe is pushed all the way to the tip (no air gap!), then thread into the lever bleed port.

**NOTE: IT IS NOT NECESSARY TO REPOSITION THE ANGLE OF THE BRAKE LEVER ON THE HANDLEBAR. YOU MAY HAVE A SMALL AMOUNT OF DOT FLUID DRIP FROM THE BLEED PORT SCREW, THIS IS NORMAL. JUST HAVE A TOWEL HANDY TO WIPE OFF ANY EXCESS AFTER THE SYRINGE IS INSTALLED.**

16



### BLEED THE SYSTEM: BLEED THE HOSE

15. Hold the caliper syringe upright in your right hand and the lever syringe upright in your left hand.
16. Gently push on the caliper syringe plunger to move fluid from the caliper syringe into the lever syringe until the lever syringe is increased to 1/2 full and the caliper syringe is decreased to 1/4 full.

**NOTE: YOU SHOULD SEE BUBBLES FILL INTO THE LEVER SYRINGE.**

17



18



17. Close the red syringe clamp on the lever.
18. Pull the brake lever all the way to the bar with your finger and hold it there until instructed to release the lever in a later step. If you don't want to hold the lever with your finger, have a friend hold it or you can fasten it with a toe strap or rubber bands.

## BLEEDING PROCEDURE (CONT)

### BLEED THE SYSTEM: BLEED THE CALIPER

19. With your right hand, gently pull out on the caliper syringe plunger to create a vacuum then gently push in on the plunger to pressurize the system. Repeat this procedure several times, until large bubbles stop coming out of the caliper.

**NOTE: BE CAREFUL NOT PULL OUT TOO HARD ON THE PLUNGER OR YOU WILL PULL AIR PAST THE PLUNGER SEAL AND YOU WILL BE THERE ALL DAY TRYING TO GET BUBBLES OUT.**

20. Once the large bubbles at the caliper have stopped, apply a small amount of pressure on the syringe plunger and slowly let the pressure extend the brake lever you have been holding with your finger. If you fastened the lever with a toe strap or rubber bands, remove these first but keep the lever pulled in with your finger, then apply pressure on the syringe plunger (not pictured).

**NOTE: YOU WILL FEEL THE PRESSURE AT YOUR FINGER ON THE LEVER, JUST LET THE FLUID EXTEND THE LEVER BACK TO ITS ORIGINAL POSITION.**

21. Remove the syringe from the caliper and re-install the bleed port screw.

**NOTE: THERE WILL BE EXCESS DOT FLUID THAT SPILLS OUT AS YOU RE-INSTALL THE BLEED PORT SCREW, THIS IS NORMAL. BE SURE TO WIPE THE FLUID OFF THE CALIPER WITH A TOWEL AND WATER.**

19



21



22



23



24



### BLEED THE SYSTEM: BLEED THE LEVER

22. Open the red syringe clamp on the lever.
23. Gently pull out on the lever syringe plunger to create a vacuum, then gently push in on plunger to pressurize the system. Squeeze and release the brake lever ten times, allowing the lever to snap back to its starting position after squeezing (this helps break loose the bubbles). Repeat this procedure several times, until large bubbles stop coming out of the lever.

**NOTE: BE CAREFUL NOT PULL OUT TOO HARD ON THE PLUNGER OR YOU WILL SUCK AIR PAST THE PLUNGER SEAL INTO THE FLUID AND CREATE MORE BUBBLES THAT YOU WILL HAVE TO ELIMINATE.**

24. Once the large bubbles at the lever have stopped, apply a small amount of pressure on the syringe plunger then remove the syringe and re-install the bleed port screw.

**NOTE: THERE WILL BE A SMALL AMOUNT OF EXCESS DOT FLUID THAT SPILLS OUT AS YOU REMOVE THE SYRINGE AND RE-INSTALL THE BLEED PORT SCREW, THIS IS NORMAL. BE SURE TO WIPE THE FLUID OFF THE LEVER WITH A TOWEL.**

## BLEEDING PROCEDURE (CONT)

### FINAL TOUCH (NOT PICTURED)

25. Spray isopropyl alcohol or water onto a towel and wipe off the brake lever and caliper to remove any excess DOT fluid you may have missed before.
26. Remove the Bleed Block from the caliper and re-install the brake pads and spreader clip.
27. Re-install your wheel according to the manufacturer's instructions.

## CLEAN UP

Empty the syringes into a sealed container and dispose of the fluid properly. Remember, used DOT fluid should be recycled or disposed of in accordance to local and federal regulations.

NEVER pour used DOT fluid down a sewage or drainage system or into the ground or a body of water.

Do not re-use this fluid.

Do not leave the hose clamps closed, this will damage the clear tubing on the syringes.

## TEST THE SYSTEM

You are almost ready to ride, but first it's a good idea to test your brakes. Pull on the lever extremely hard (as hard as you can imagine yourself pulling the lever while you're riding) several times. Make sure and look around the hose nut on the lever, and the banjo bolt on the caliper for any leaks. Make one last check of all the bolts and fittings.

If everything checks out, **YOU ARE READY TO RIDE!**



# **DISC BRAKE PAD REPLACEMENT**

# ELIXIR R, CR

## INTRODUCTION

Avid brake pads should be replaced when the total thickness of the backing plate and pad friction material is less than 3mm. Replacing worn brake pads will improve braking performance. New brake pads are subject to a “break-in” period. It may take anywhere from 20 to 40 complete stops to break in Avid pads. You may begin to notice an increase in braking power after the first ride. Brake noise can occur during the break-in period, as well as off and on throughout the life of the brake pads. This is normal and should not affect braking performance. Noise is dependent upon factors such as brake setup, rider weight, riding style, braking style, and riding conditions (i.e. dust, soil, and contamination of friction surfaces).

## PAD REPLACEMENT

### REMOVE PAD RETAINER BOLT

1. Start by removing the “E” clip on the wheel side of the caliper, then unscrew the retainer bolt using a 2.5 mm hex wrench. Remove the retainer bolt all the way.

1



3



### PUSH THE PISTONS BACK IN

2. The Elixir calipers are self adjusting, the pistons need to be pushed back into the body to their original position before the new pads can be installed. The safest way to do this is with the old pads still in the caliper to protect the pistons. Place a flat-blade screwdriver between the old pads, then carefully rock it back and forth, pushing the pistons back into their bores (not pictured).

5



6

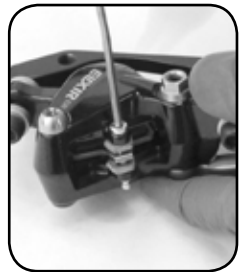

### REMOVE THE OLD PADS

3. Grab the pad tabs and pull straight out.
4. Inspect and measure the total thickness of each brake pad with a ruler. If the total thickness is less than 3 mm, you need to replace both brake pads (not pictured).

**NOTE: IF THE BACKING PLATE AND PAD MATERIAL IS THICKER THAN 3 MM, YOU CAN SIMPLY RE-INSTALL YOUR BRAKE PADS AS OUTLINED IN STEP 5.**

### INSTALL THE NEW PADS AND SPREADER

5. Be sure the spreader clip is oriented to the pads as shown. Align the hole in the spreader clip with the holes in the pad tabs. Squeeze the pad and clip assembly together, then insert into the caliper as a unit. Firmly push until the assembly is seated into place.
6. Install the pad retainer bolt and tighten to 0.9-1.1 N·m (80-97 in·lb). Install the “E” clip on the wheel side of the caliper making sure it sits in the groove of the retainer bolt.



**THIS CONCLUDES THE DISC BRAKE PAD REPLACEMENT INSTRUCTIONS. YOU DID A GREAT JOB! YOU ARE NOW READY TO RIDE. ENJOY!**

# JUICY 3, 5, 7, CARBON, ULTIMATE

## INTRODUCTION

Avid brake pads should be replaced when the total thickness of the backing plate and pad friction material is less than 3mm. Replacing worn brake pads will improve braking performance. New brake pads are subject to a “break-in” period. It may take anywhere from 20 to 40 complete stops to break in Avid pads. You may begin to notice an increase in braking power after the first ride. Brake noise can occur during the break-in period, as well as off and on throughout the life of the brake pads. This is normal and should not affect braking performance. Noise is dependent upon factors such as brake setup, rider weight, riding style, braking style, and riding conditions (i.e. dust, soil, and contamination of friction surfaces).

## PAD REPLACEMENT

### PUSH THE PISTONS BACK IN

1. The Juicy calipers are self adjusting. Therefore, the pistons need to be pushed back into their original position in the body before the new pads can be installed. The best way to do this is with the old pads still in the caliper to protect the pistons. Place a flat-blade screwdriver between the old pads and gently rock it back and forth, pushing the pistons back into their bores (not pictured).



### REMOVE THE OLD PADS AND H-SPRING

2. Using needle-nosed pliers, grab one of the pad tabs and slide the pad toward the center of the caliper (this disengages the pad backing plate from the post in the center of the piston), then pull the pad straight out. Repeat for other pad.

**NOTE: IF THE H-SPRING DOESN'T COME OUT WITH THE SECOND PAD, PUSH IT OUT FROM THE OPEN TOP OF THE CALIPER WITH A PICK OR YOUR FINGER.**

3. Remove the spring pad clip from the outside of the caliper.
4. Inspect and measure the total thickness of each brake pad with a ruler. If the total thickness is less than 3 mm, you need to replace both brake pads (not pictured).



**NOTE: IF THE BACKING PLATE AND PAD MATERIAL IS THICKER THAN 3 MM, YOU CAN SIMPLY RE-INSTALL YOUR BRAKE PADS AS OUTLINED IN STEP 5.**

### INSTALL THE NEW PADS AND H-SPRING

5. Position the h-spring between the two pads. The curved handle of inner pad should face toward the inboard side of the caliper. Squeeze the pad and spring assembly together, then firmly push into the caliper until it ‘clicks’ into place, indicating it is properly secured in the caliper body.

**THIS CONCLUDES THE DISC BRAKE PAD REPLACEMENT INSTRUCTIONS. YOU DID A GREAT JOB! YOU ARE NOW READY TO RIDE. ENJOY!**

# CODE, CODE 5

## INTRODUCTION

Avid brake pads should be replaced when the total thickness of the backing plate and pad friction material is less than 3mm. Replacing worn brake pads will improve braking performance. New brake pads are subject to a “break-in” period. It may take anywhere from 20 to 40 complete stops to break in Avid pads. You may begin to notice an increase in braking power after the first ride. Brake noise can occur during the break-in period, as well as off and on throughout the life of the brake pads. This is normal and should not affect braking performance. Noise is dependent upon factors such as brake setup, rider weight, riding style, braking style, and riding conditions (i.e. dust, soil, and contamination of friction surfaces).

## PAD REPLACEMENT

### REMOVE OLD BRAKE PADS AND H-SPRING

1. Remove e-clip from guide pin groove on top of the caliper using a sharp pick.
2. Using a 2.5 mm hex wrench remove the guide pin from the caliper.
3. Squeeze the pads together so they clear the piston, and pull to remove brake pads and h-spring from caliper.
4. Inspect and measure the total thickness of each brake pad with a ruler or the pad thickness slot on the pad spacer tool. If the total thickness is less than 3 mm, or it fits into the slot, you need to replace both brake pads (not pictured).

**NOTE: IF THE BACKING PLATE AND PAD MATERIAL IS THICKER THAN 3 MM OR THE SLOT, YOU CAN SIMPLY RE-INSTALL YOUR BRAKE PADS AS OUTLINED IN STEPS 5-10.**

### INSTALL THE NEW PADS AND H-SPRING

5. Position the h-spring between the two pads.  
**NOTE: THE CODE PADS ARE SYMMETRICAL, THERE IS NOT A LEFT OR RIGHT ORIENTATION.**
6. Locate the pad installation feature of the pad spacer tool. Insert the pad handles into the pad installation tool so it holds the pads together.
7. Insert the pads and pad tool into the caliper until the holes in the top of the pads are aligned with the guide pin holes in the top of the caliper.
8. Insert the guide pin through the caliper body halves and the brake pads. Using a 2.5 mm hex wrench, tighten the guide pin to 0.9-1.1 N·m (80-97 in-lb).
9. Remove the pad tool. The h-spring will snap the pads into position.
10. Using your thumb or finger, install the e-clip into the groove on the end of the guide pin.

**THIS CONCLUDES THE DISC BRAKE PAD REPLACEMENT INSTRUCTIONS. YOU DID A GREAT JOB! YOU ARE NOW READY TO RIDE. ENJOY!**

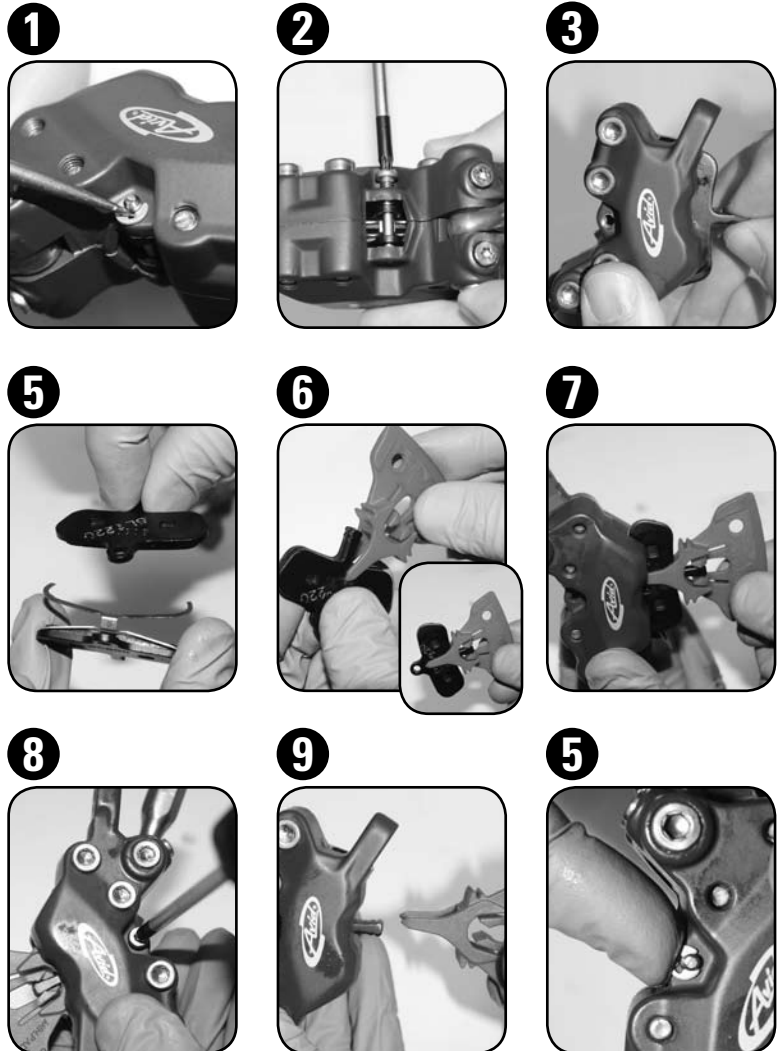



# BB7 MOUNTAIN & ROAD

## INTRODUCTION

Avid brake pads should be replaced when the total thickness of the backing plate and pad friction material is less than 3mm. Replacing worn brake pads will improve braking performance. New brake pads are subject to a “break-in” period. It may take anywhere from 20 to 40 complete stops to break in Avid pads. You may begin to notice an increase in braking power after the first ride. Brake noise can occur during the break-in period, as well as off and on throughout the life of the brake pads. This is normal and should not affect braking performance. Noise is dependent upon factors such as brake setup, rider weight, riding style, braking style, and riding conditions (i.e. dust, soil, and contamination of friction surfaces).

## PAD REPLACEMENT

### REMOVE THE OLD PADS

1. Turn both adjuster knobs all the way out (counterclockwise), then squeeze the pad tabs together and pull both pads and pad spring clip straight out of the caliper.
2. Inspect and measure the total thickness of each brake pad with a ruler. If the total thickness is less than 3 mm, you need to replace both brake pads (not pictured).

**NOTE: IF THE BACKING PLATE AND PAD MATERIAL IS THICKER THAN 3 MM, YOU CAN SIMPLY RE-INSTALL YOUR BRAKE PADS AS OUTLINED IN STEP 3 AND FOLLOW THE PROCEDURES FOR PAD WEAR ADJUSTMENT.**

1



3



### INSTALL THE NEW PADS AND SPRING

3. Assemble the spring between the new left and right pads. Align the spring to the pad as shown. Squeeze the brake pad and spring clip assembly together then press firmly into the caliper until it “clicks” into place. The pad marked “R” goes on the spoke side of the brake.



### PAD WEAR ADJUSTMENT (NOT PICTURED)

The BB7 has a manual pad wear adjustment feature. You can use this feature to compensate for brake pad wear until the pads need to be replaced with two very simple adjustments: Turn both the inboard and outboard red adjusting knobs clockwise one or two clicks as needed to restore your brake to optimum settings. Do NOT use your barrel adjuster to compensate for pad wear. A pad wear indicator is at the center of each knob. As the knob is turned in, the indicator will retract deeper into the knob giving a visual indication of approximately how much the pads have worn.

**THIS CONCLUDES THE DISC BRAKE PAD REPLACEMENT INSTRUCTIONS. YOU HAVE DONE A GREAT JOB! YOU ARE NOW READY TO RIDE. ENJOY!**

[www.sram.com](http://www.sram.com)

**WORLD HEADQUARTERS**

SRAM Corporation  
1333 N. Kingsbury St., 4th Fl  
Chicago, IL 60622  
USA  
Phone +1-312-664-8800  
Fax +1-312-664-8826

**EUROPEAN HEADQUARTERS**

SRAM Europe  
Basicweg 12-d  
3821 Br Amersfoort  
The Netherlands  
Phone +31-33-450-6060  
Fax +31-33-457-0200

**ASIAN HEADQUARTERS**

SRAM Taiwan  
No. 1598-8 Chung Sahn Rd  
Shen Kang Hsiang, Taichung  
County 429 Taiwan R.O.C.  
Phone +886-4-2564-3678  
Fax +886-4-2561-3686